

Version 1.0

Published June 2020

Copyright©2020 ASRock INC. All rights reserved.



Copyright Notice:

No part of this documentation may be reproduced, transcribed, transmitted, or translated in any language, in any form or by any means, except duplication of documentation by the purchaser for backup purpose, without written consent of ASRock Inc.

Products and corporate names appearing in this documentation may or may not be registered trademarks or copyrights of their respective companies, and are used only for identification or explanation and to the owners' benefit, without intent to infringe.

Disclaimer:

Specifications and information contained in this documentation are furnished for informational use only and subject to change without notice, and should not be construed as a commitment by ASRock. ASRock assumes no responsibility for any errors or omissions that may appear in this documentation.

With respect to the contents of this documentation, ASRock does not provide warranty of any kind, either expressed or implied, including but not limited to the implied warranties or conditions of merchantability or fitness for a particular purpose.

In no event shall ASRock, its directors, officers, employees, or agents be liable for any indirect, special, incidental, or consequential damages (including damages for loss of profits, loss of business, loss of data, interruption of business and the like), even if ASRock has been advised of the possibility of such damages arising from any defect or error in the documentation or product.



This device complies with Part 15 of the FCC Rules. Operation is subject to the following two conditions:

- (1) this device may not cause harmful interference, and
- (2) this device must accept any interference received, including interference that may cause undesired operation.

CALIFORNIA, USA ONLY

The Lithium battery adopted on this motherboard contains Perchlorate, a toxic substance controlled in Perchlorate Best Management Practices (BMP) regulations passed by the California Legislature. When you discard the Lithium battery in California, USA, please follow the related regulations in advance.

“Perchlorate Material-special handling may apply, see www.dtsc.ca.gov/hazardouswaste/perchlorate”

ASRock Website: <http://www.asrock.com>

AUSTRALIA ONLY

Our goods come with guarantees that cannot be excluded under the Australian Consumer Law. You are entitled to a replacement or refund for a major failure and compensation for any other reasonably foreseeable loss or damage caused by our goods. You are also entitled to have the goods repaired or replaced if the goods fail to be of acceptable quality and the failure does not amount to a major failure. If you require assistance please call ASRock Tel : +886-2-28965588 ext.123 (Standard International call charges apply)

The terms HDMI® and HDMI High-Definition Multimedia Interface, and the HDMI logo are trademarks or registered trademarks of HDMI Licensing LLC in the United States and other countries.



CE Warning

This device complies with directive 2014/53/EU issued by the Commission of the European Community.

This equipment complies with EU radiation exposure limits set forth for an uncontrolled environment.

This equipment should be installed and operated with minimum distance 20cm between the radiator & your body.

Operations in the 5.15-5.35GHz band are restricted to indoor usage only.

	AT	BE	BG	CH	CY	CZ	DE
	DK	EE	EL	ES	FI	FR	HR
	HU	IE	IS	IT	LI	LT	LU
	LV	MT	NL	NO	PL	PT	RO
	SE	SI	SK	TR	UK		



Radio transmit power per transceiver type

Function	Frequency	Maximum Output Power (EIRP)
WiFi	2400-2483.5 MHz	18.5 + / -1.5 dbm
	5150-5250 MHz	21.5 + / -1.5 dbm
	5250-5350 MHz	18.5 + / -1.5 dbm (no TPC)
		21.5 + / -1.5 dbm (TPC)
	5470-5725 MHz	25.5 + / -1.5 dbm (no TPC)
Bluetooth		28.5 + / -1.5 dbm (TPC)
	2400-2483.5 MHz	8.5 + / -1.5 dbm

Motherboard Layout

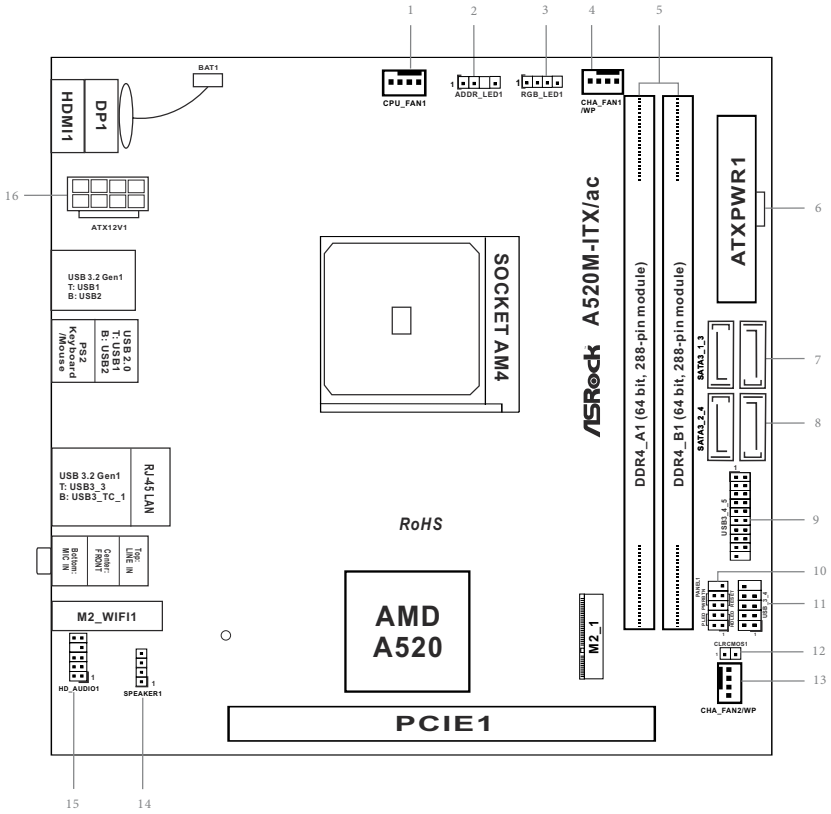

No.	Description
1	CPU Fan Connector (CPU_FAN1)
2	Addressable LED Header (ADDR_LED1)
3	RGB LED Header (RGB_LED1)
4	Chassis/Water Pump Fan Connector (CHA_FAN1/WP)
5	2 x 288-pin DDR4 DIMM Slots (DDR4_A1, DDR4_B1)
6	ATX Power Connector (ATXPWR1)
7	SATA3 Connectors (SATA3_1_3)
8	SATA3 Connectors (SATA3_2_4)
9	USB 3.2 Gen1 Header (USB3_4_5)
10	System Panel Header (PANEL1)
11	USB 2.0 Header (USB_3_4)
12	Clear CMOS Jumper (CLRCMOS1)
13	Chassis/Water Pump Fan Connector (CHA_FAN2/WP)
14	Chassis Speaker Header (SPEAKER1)
15	Front Panel Audio Header (HD_AUDIO1)
16	ATX 12V Power Connector (ATX12V1)

I/O Panel

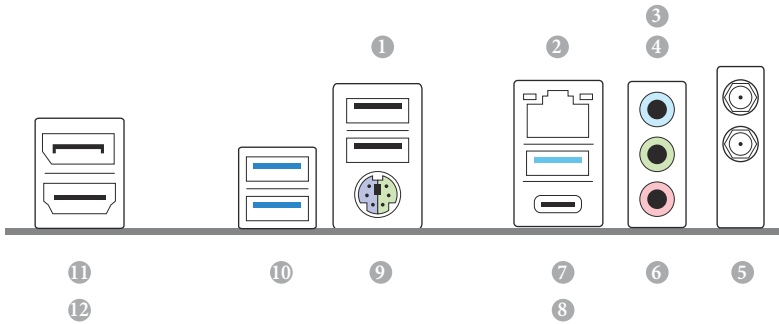

No.	Description	No.	Description
1	USB 2.0 Ports (USB_12)*	7	USB 3.2 Gen1 Type-A Port (USB3_3)
2	LAN RJ-45 Port**	8	USB 3.2 Gen1 Type-C Port (USB3_TC_1)
3	Line In (Light Blue)***	9	PS/2 Mouse/Keyboard Port
4	Front Speaker (Lime)***	10	USB 3.2 Gen1 Type-A Port (USB3_1_2)
5	Antenna Ports	11	DisplayPort 1.4
6	Microphone (Pink)***	12	HDMI Port

* Please note that the USB_12 consume auxiliary power (+5VSB) while the other USB ports consume DUAL Power (+5VDUAL). The USB_12 are optimal for connecting the USB Type speaker and headset..

** There are two LEDs on each LAN port. Please refer to the table below for the LAN port LED indications.

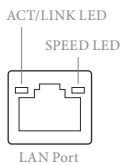

Activity / Link LED		Speed LED	
Status	Description	Status	Description
Off	No Link	Off	10Mbps connection
Blinking	Data Activity	Orange	100Mbps connection
On	Link	Green	1Gbps connection

*** Function of the Audio Ports in 7.1-channel Configuration:

Port	Function
Light Blue (Rear panel)	Rear Speaker Out
Lime (Rear panel)	Front Speaker Out
Pink (Rear panel)	Central /Subwoofer Speaker Out
Lime (Front panel)	Side Speaker Out

WiFi-802.11ac Module and ASRock WiFi 2.4/5 GHz Antennas

WiFi-802.11ac + BT Module

This motherboard comes with an exclusive WiFi 802.11 a/b/g/n/ac + BT v4.2 module (pre-installed on the rear I/O panel) that offers support for WiFi 802.11 a/b/g/n/ac connectivity standards and Bluetooth v4.2. WiFi + BT module is an easy-to-use wireless local area network (WLAN) adapter to support WiFi + BT. Bluetooth v4.2 standard features Smart Ready technology that adds a whole new class of functionality into the mobile devices. BT 4.2 also includes Low Energy Technology and ensures extraordinary low power consumption for PCs.

* The transmission speed may vary according to the environment.

WiFi Antennas Installation Guide



Step 1

Prepare the WiFi 2.4/5 GHz Antennas that come with the package.

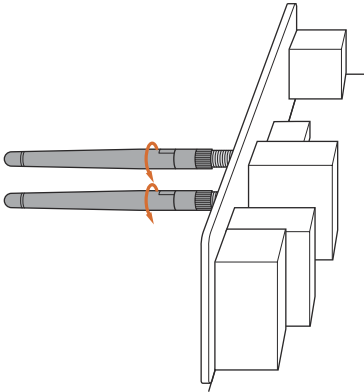

Step 2

Connect the two WiFi 2.4/5 GHz Antennas to the antenna connectors. Turn the antenna clockwise until it is securely connected.

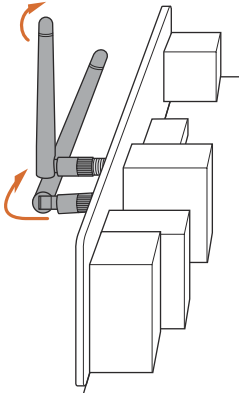

Step 3

Set the WiFi 2.4/5 GHz Antenna as shown in the illustration.

*You may need to adjust the direction of the antenna for a stronger signal.

Chapter 1 Introduction

Thank you for purchasing ASRock A520M-ITX/ac motherboard, a reliable motherboard produced under ASRock's consistently stringent quality control. It delivers excellent performance with robust design conforming to ASRock's commitment to quality and endurance.



Because the motherboard specifications and the BIOS software might be updated, the content of this documentation will be subject to change without notice. In case any modifications of this documentation occur, the updated version will be available on ASRock's website without further notice. If you require technical support related to this motherboard, please visit our website for specific information about the model you are using. You may find the latest VGA cards and CPU support list on ASRock's website as well. ASRock website <http://www.asrock.com>.

1.1 Package Contents

- ASRock A520M-ITX/ac Motherboard (Mini-ITX Form Factor)
- ASRock A520M-ITX/ac Quick Installation Guide
- ASRock A520M-ITX/ac Support CD
- 1 x I/O Panel Shield
- 2 x Serial ATA (SATA) Data Cables (Optional)
- 2 x ASRock WiFi 2.4/5 GHz Antennas (Optional)

1.2 Specifications

- Platform**
- Mini-ITX Form Factor
 - Solid Capacitor design

- CPU**
- Supports 3rd Gen AMD AM4 Ryzen™ / future AMD Ryzen™ Processors (3000 and 4000 Series Processors)*
- * Not compatible with AMD Ryzen™ 5 3400G and Ryzen™ 3 3200G.
- Digi Power design
 - 8 Power Phase design

- Chipset**
- AMD A520

- Memory**
- Dual Channel DDR4 Memory Technology
 - 2 x DDR4 DIMM Slots
 - AMD Ryzen series CPUs (Matisse) support DDR4 4600+(OC)/4533(OC)/4466(OC)/4400(OC)/4333(OC)/4333(OC)/4266(OC)/4200(OC)/4133(OC)/4000(OC)/3866(OC)/3800(OC)/3733(OC)/3600(OC)/3466(OC)/3200/2933/2667/2400/2133 ECC & non-ECC, un-buffered memory*
 - AMD Ryzen series APUs (Renoir) support DDR4 4733+(OC)/4666(OC)/4600(OC)/4533(OC)/4466(OC)/4400(OC)/4333(OC)/4266(OC)/4200(OC)/4133(OC)/4000(OC)/3866(OC)/3800(OC)/3733(OC)/3600(OC)/3466(OC)/3200/2933/2667/2400/2133 ECC & non-ECC, un-buffered memory*
- * Please refer to Memory Support List on ASRock's website for more information. (<http://www.asrock.com/>)
- * Please refer to page 24 for DDR4 UDIMM maximum frequency support.
- Max. capacity of system memory: 64GB
 - Supports Extreme Memory Profile (XMP) memory modules
 - 15μ Gold Contact in DIMM Slots

Expansion Slot

- 1 x PCI Express 3.0 x16 Slot (PCI-E1: x16 mode)*
- * AMD Ryzen series CPUs (Matisse) supports PCIe riser cards to extend x8/x8 slots
- * Supports NVMe SSD as boot disks
- 1 x Vertical M.2 Socket (Key E) with the bundled WiFi-802.11ac module (on the rear I/O)

Graphics

- Integrated AMD Radeon™ Vega Series Graphics in Ryzen Series APU*
- * Actual support may vary by CPU
- DirectX 12, Pixel Shader 5.0
- Shared memory default 2GB. Max Shared memory supports up to 16GB.
- * The Max shared memory 16GB requires 32GB system memory installed.
- Dual graphics output: support HDMI and DisplayPort 1.4 ports by independent display controllers
- Supports HDMI 2.1 with max. resolution up to 4K x 2K (4096x2160) @ 60Hz
- Supports DisplayPort 1.4 Input with max. resolution up to 5K (5120x2880)@120Hz
- Supports Auto Lip Sync, Deep Color (12bpc), xvYCC and HBR (High Bit Rate Audio) with HDMI 2.1 Port (Compliant HDMI monitor is required)
- Supports HDR (High Dynamic Range) with HDMI 2.1
- Supports HDCP 2.3 with HDMI 2.1 and DisplayPort 1.4 Ports
- Supports 4K Ultra HD (UHD) playback with HDMI 2.1 and DisplayPort 1.4 Ports
- Supports Microsoft PlayReady®

Audio

- 7.1 CH HD Audio (Realtek ALC887 Audio Codec)
- Supports Surge Protection

LAN

- PCIE x1 Gigabit LAN 10/100/1000 Mb/s
- Realtek RTL8111H
- Supports Wake-On-LAN
- Supports Lightning/ESD Protection
- Supports Energy Efficient Ethernet 802.3az
- Supports PXE

**Wireless
LAN**

- Intel® 802.11ac WiFi Module
- Supports IEEE 802.11a/b/g/n/ac
- Supports Dual-Band (2.4/5 GHz)
- Supports high speed wireless connections up to 433Mbps
- Supports Bluetooth 4.2+ High speed class II

**Rear Panel
I/O**

- 2 x Antenna Ports
- 1 x PS/2 Mouse/Keyboard Port
- 1 x HDMI Port
- 1 x DisplayPort 1.4
- 2 x USB 2.0 Ports (Supports ESD Protection)
- 3 x USB 3.2 Gen1 Type-A Ports (Supports ESD Protection)
- 1 x USB 3.2 Gen1 Type-C Port (Supports ESD Protection)
- 1 x RJ-45 LAN Port with LED (ACT/LINK LED and SPEED LED)
- HD Audio Jacks: Line in / Front Speaker / Microphone

Storage

- 4 x SATA3 6.0 Gb/s Connectors, support RAID (RAID 0, RAID 1 and RAID 10), NCQ, AHCI and Hot Plug
- 1 x Ultra M.2 Socket (M2_1), supports M Key type 2280 M.2 SATA3 6.0 Gb/s module and M.2 PCI Express module up to Gen3 x4 (32 Gb/s)*

* Supports NVMe SSD as boot disks

* Supports ASRock U.2 Kit

Connector

- 1 x RGB LED Header
- * Supports in total up to 12V/3A, 36W LED Strip
- 1 x Addressable LED Header
- * Supports in total up to 5V/3A, 15W LED Strip
- 1 x CPU Fan Connector (4-pin)
- * The CPU Fan Connector supports the CPU fan of maximum 1A (12W) fan power.

- 2 x Chassis/Water Pump Fan Connectors (4-pin) (Smart Fan Speed Control)
- * The Chassis/Water Pump Fan supports the water cooler fan of maximum 2A (24W) fan power.
- * CHA_FAN1/WP and CHA_FAN2/WP can auto detect if 3-pin or 4-pin fan is in use.
- 1 x 24 pin ATX Power Connector
- 1 x 8 pin 12V Power Connector
- 1 x Front Panel Audio Connector
- 1 x USB 2.0 Header (Supports 2 USB 2.0 ports) (Supports ESD Protection)
- 1 x USB 3.2 Gen1 Header (Supports 2 USB 3.2 Gen1 ports) (Supports ESD Protection)

BIOS Feature

- AMI UEFI Legal BIOS with GUI support
- Supports “Plug and Play”
- ACPI 5.1 compliance wake up events
- Supports jumperfree
- SMBIOS 2.3 support
- CPU, CPU VDDCR_SOC, DRAM, VPPM, +1.8VSB, VDDP Voltage Multi-adjustment

Hardware Monitor

- Temperature Sensing: CPU, Chassis/Water Pump Fans
- Fan Tachometer: CPU, Chassis/Water Pump Fans
- Quiet Fan (Auto adjust chassis fan speed by CPU temperature): CPU, Chassis/Water Pump Fans
- Fan Multi-Speed Control: CPU, Chassis/Water Pump Fans
- Voltage monitoring: +12V, +5V, +3.3V, CPU Vcore

OS

- Microsoft® Windows® 10 64-bit

Certifica- tions

- FCC, CE
- ErP/EuP ready (ErP/EuP ready power supply is required)

* For detailed product information, please visit our website: <http://www.asrock.com>



Please realize that there is a certain risk involved with overclocking, including adjusting the setting in the BIOS, applying Untied Overclocking Technology, or using third-party overclocking tools. Overclocking may affect your system's stability, or even cause damage to the components and devices of your system. It should be done at your own risk and expense. We are not responsible for possible damage caused by overclocking.

Chapter 2 Installation

This is a Mini-ITX form factor motherboard. Before you install the motherboard, study the configuration of your chassis to ensure that the motherboard fits into it.

Pre-installation Precautions

Take note of the following precautions before you install motherboard components or change any motherboard settings.

- Make sure to unplug the power cord before installing or removing the motherboard. Failure to do so may cause physical injuries to you and damages to motherboard components.
- In order to avoid damage from static electricity to the motherboard's components, NEVER place your motherboard directly on a carpet. Also remember to use a grounded wrist strap or touch a safety grounded object before you handle the components.
- Hold components by the edges and do not touch the ICs.
- Whenever you uninstall any components, place them on a grounded anti-static pad or in the bag that comes with the components.
- When placing screws to secure the motherboard to the chassis, please do not over-tighten the screws! Doing so may damage the motherboard.

2.1 Installing the CPU



Unplug all power cables before installing the CPU.

1

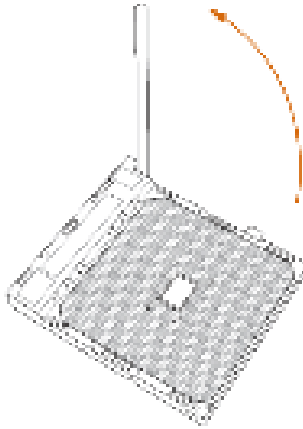

2



3

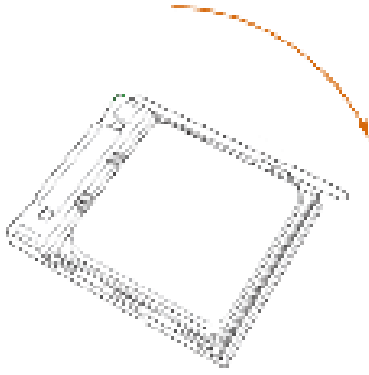

2.2 Installing the CPU Fan and Heatsink

After you install the CPU into this motherboard, it is necessary to install a larger heatsink and cooling fan to dissipate heat. You also need to spray thermal grease between the CPU and the heatsink to improve heat dissipation. Make sure that the CPU and the heatsink are securely fastened and in good contact with each other.



Please turn off the power or remove the power cord before changing a CPU or heatsink.

Installing the CPU Box Cooler SR1

1

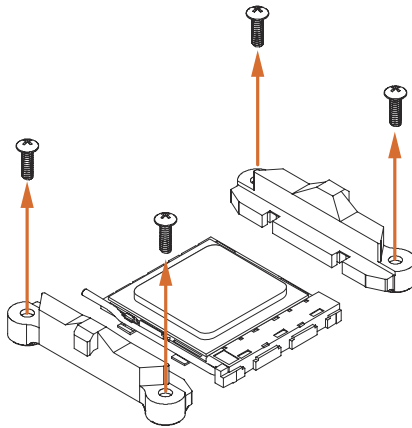

2

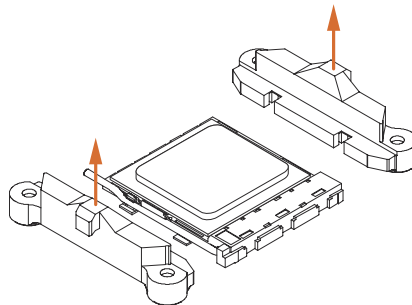

3

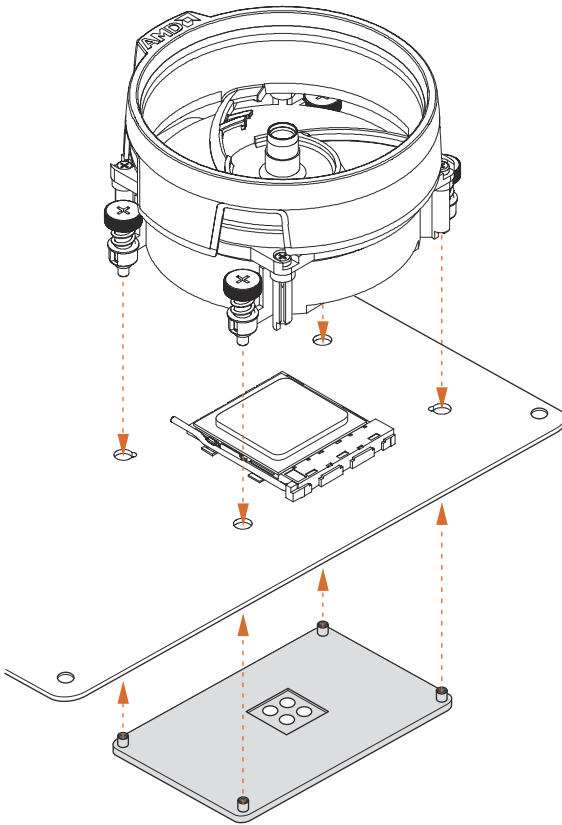

4

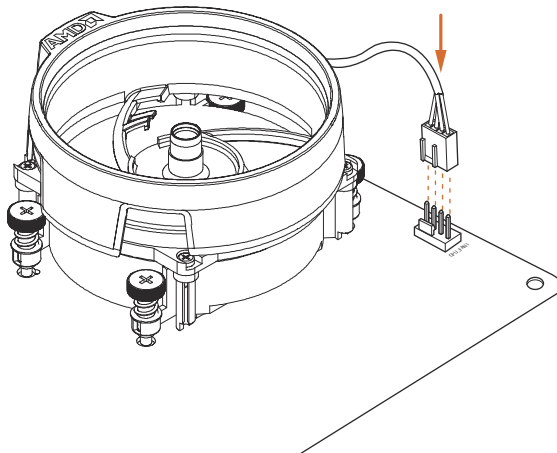

Installing the AM4 Box Cooler SR2

1

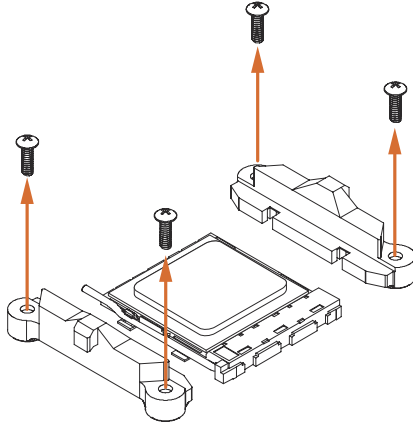

2

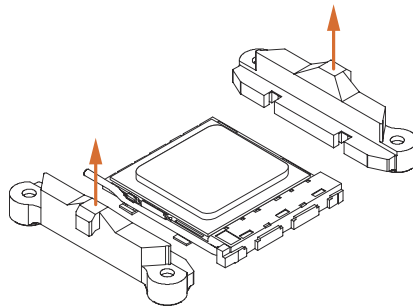

3

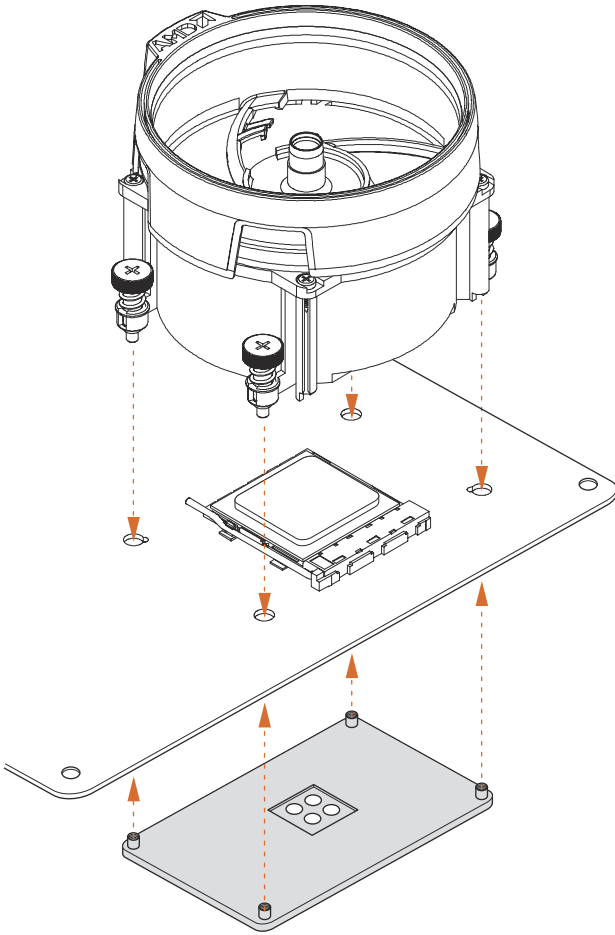

4

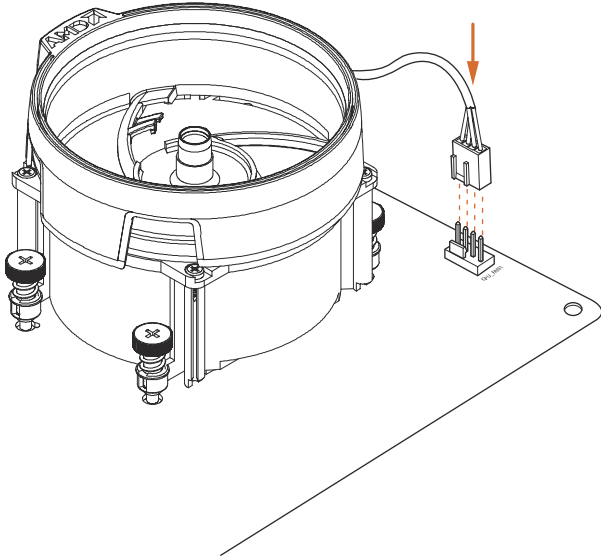

*The diagrams shown here are for reference only. The headers might be in a different position on your motherboard.

Installing the AM4 Box Cooler SR3

1

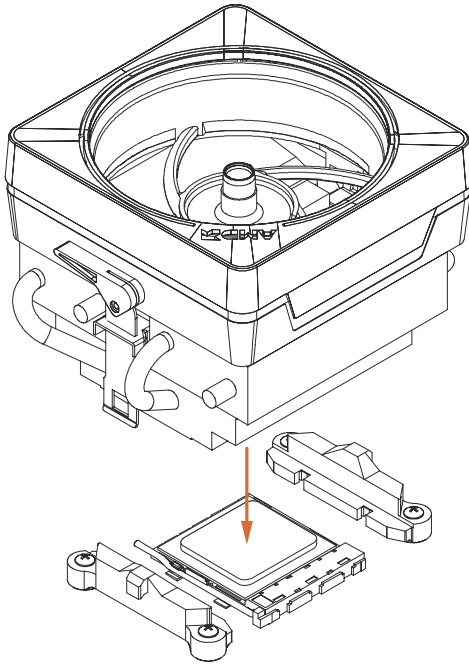

2

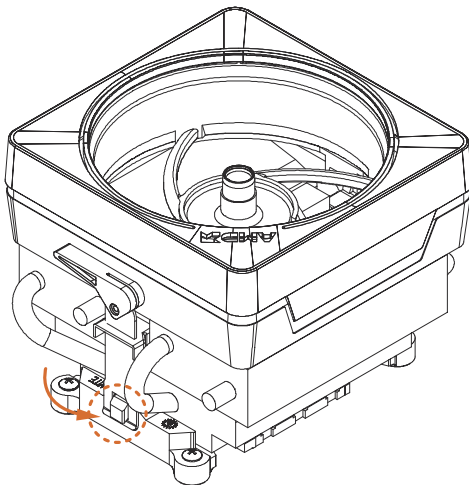

3

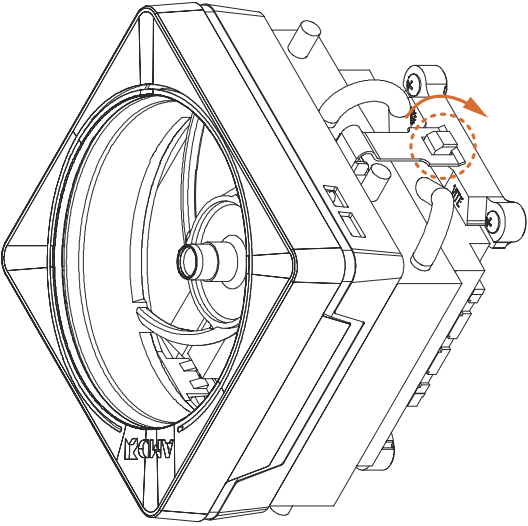

4

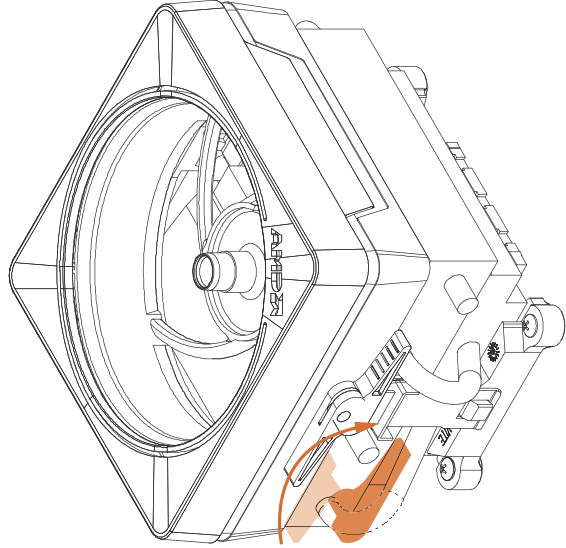

5

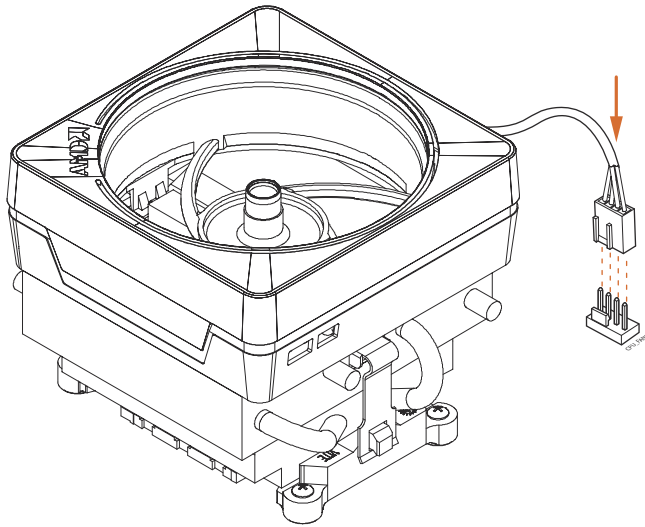

6

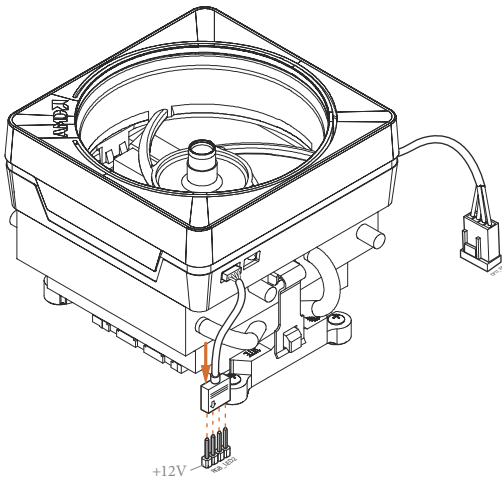

*The diagrams shown here are for reference only. The headers might be in a different position on your motherboard.

2.3 Installing Memory Modules (DIMM)

This motherboard provides two 288-pin DDR4 (Double Data Rate 4) DIMM slots, and supports Dual Channel Memory Technology.



1. For dual channel configuration, you always need to install identical (the same brand, speed, size and chip-type) DDR4 DIMM pairs.
2. It is unable to activate Dual Channel Memory Technology with only one memory module installed.
3. It is not allowed to install a DDR, DDR2 or DDR3 memory module into a DDR4 slot; otherwise, this motherboard and DIMM may be damaged.

AMD non-XMP Memory Frequency Support

Ryzen Series CPUs (Matisse):

UDIMM Memory Slot		Frequency
A1	B1	(Mhz)
SR	-	3200
-	SR	3200
DR	-	3200
-	DR	3200
SR	SR	3200
DR	DR	3200

Ryzen Series APUs (Renoir):

UDIMM Memory Slot		Frequency
A1	B1	(Mhz)
SR	-	3200
-	SR	3200
DR	-	3200
-	DR	3200
SR	SR	3200
DR	DR	3200



The DIMM only fits in one correct orientation. It will cause permanent damage to the motherboard and the DIMM if you force the DIMM into the slot at incorrect orientation.

1

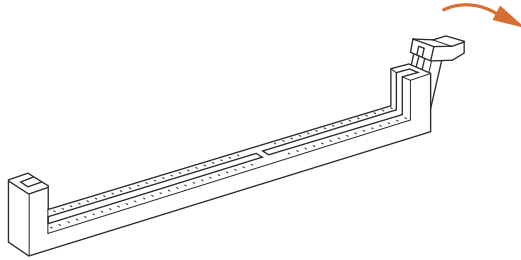

2

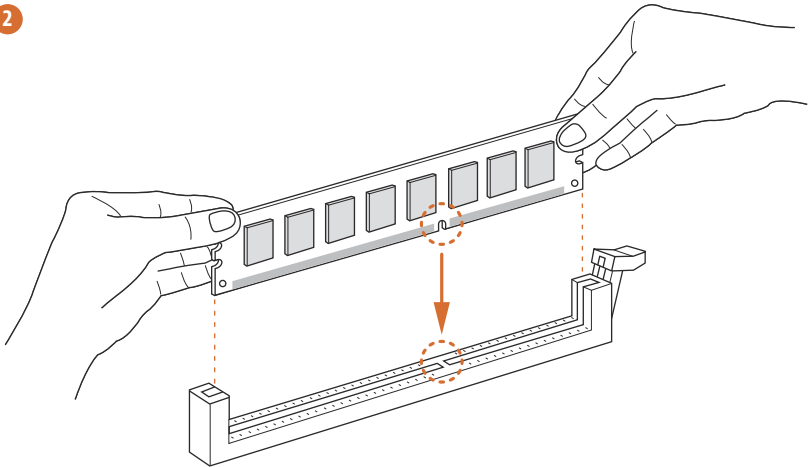

3

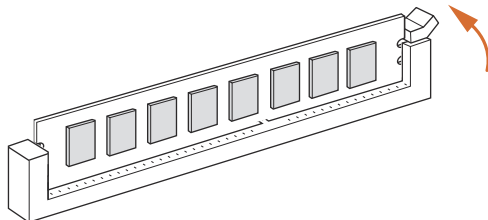

2.4 Expansion Slot (PCI Express Slot)

There is 1 PCI Express slot on the motherboard.



Before installing an expansion card, please make sure that the power supply is switched off or the power cord is unplugged. Please read the documentation of the expansion card and make necessary hardware settings for the card before you start the installation.

PCIe slots:

PCIe1 (PCIe 3.0 x16 slot) is used for PCI Express x16 lane width graphics cards.

* AMD Ryzen series CPUs (Matisse) supports PCIe riser cards to extend x8/x8 slots



For a better thermal environment, please connect a chassis fan to the motherboard's chassis fan connector (CHA_FAN1/WP or CHA_FAN2/WP) when using multiple graphics cards.

2.5 Jumpers Setup

The illustration shows how jumpers are setup. When the jumper cap is placed on the pins, the jumper is “Short”. If no jumper cap is placed on the pins, the jumper is “Open”.

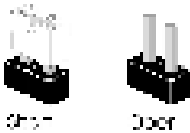

Clear CMOS Jumper
(CLR CMOS1)
(see p.1, No. 12)

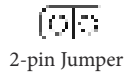

Short: Clear CMOS
Open: Default

CLR CMOS1 allows you to clear the data in CMOS. The data in CMOS includes system setup information such as system password, date, time, and system setup parameters. To clear and reset the system parameters to default setup, please turn off the computer and unplug the power cord, then use a jumper cap to short the pins on CLR CMOS1 for 3 seconds. Please remember to remove the jumper cap after clearing the CMOS. If you need to clear the CMOS when you just finish updating the BIOS, you must boot up the system first, and then shut it down before you do the clear-CMOS action.

2.6 Onboard Headers and Connectors



Onboard headers and connectors are NOT jumpers. Do NOT place jumper caps over these headers and connectors. Placing jumper caps over the headers and connectors will cause permanent damage to the motherboard.

System Panel Header
(9-pin PANEL1)
(see p.1, No. 10)

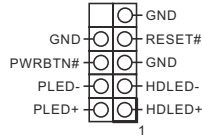

Connect the power button, reset button and system status indicator on the chassis to this header according to the pin assignments below. Note the positive and negative pins before connecting the cables.



PWRBTN (Power Button):

Connect to the power button on the chassis front panel. You may configure the way to turn off your system using the power button.

RESET (Reset Button):

Connect to the reset button on the chassis front panel. Press the reset button to restart the computer if the computer freezes and fails to perform a normal restart.

PLED (System Power LED):

Connect to the power status indicator on the chassis front panel. The LED is on when the system is operating. The LED keeps blinking when the system is in S1/S3 sleep state. The LED is off when the system is in S4 sleep state or powered off (S5).

HDLED (Hard Drive Activity LED):

Connect to the hard drive activity LED on the chassis front panel. The LED is on when the hard drive is reading or writing data.

The front panel design may differ by chassis. A front panel module mainly consists of power button, reset button, power LED, hard drive activity LED, speaker and etc. When connecting your chassis front panel module to this header, make sure the wire assignments and the pin assignments are matched correctly.

Chassis Speaker Header
(4-pin SPEAKER1)
(see p.1, No. 14)



Please connect the chassis speaker to this header.

Serial ATA3 Connectors

(SATA3_1_3:
see p.1, No. 7)
(SATA3_2_4:
see p.1, No. 8)

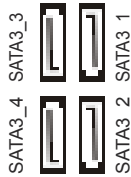

These four SATA3 connectors support SATA data cables for internal storage devices with up to 6.0 Gb/s data transfer rate.

USB 2.0 Headers

(9-pin USB_3_4)
(see p.1, No. 11)

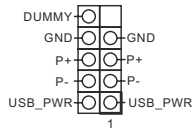

There is one header on this motherboard. This USB 2.0 header can support two ports.

USB 3.2 Gen1 Header

(19-pin USB3_4_5)
(see p.1, No. 9)

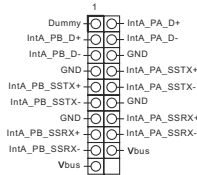

There is one header on this motherboard. This USB 3.2 Gen1 header can support two ports.

Front Panel Audio Header

(9-pin HD_AUDIO1)
(see p.1, No. 15)

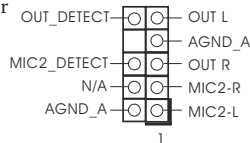

This header is for connecting audio devices to the front audio panel.



- High Definition Audio supports Jack Sensing, but the panel wire on the chassis must support HDA to function correctly. Please follow the instructions in our manual and chassis manual to install your system.
- If you use an AC'97 audio panel, please install it to the front panel audio header by the steps below:
 - Connect Mic_IN (MIC) to MIC2_L.
 - Connect Audio_R (RIN) to OUT2_R and Audio_L (LIN) to OUT2_L.
 - Connect Ground (GND) to Ground (GND).
 - MIC_RET and OUT_RET are for the HD audio panel only. You don't need to connect them for the AC'97 audio panel.
 - To activate the front mic, go to the "FrontMic" Tab in the Realtek Control panel and adjust "Recording Volume".

Chassis Water Pump Fan Connectors

(4-pin CHA_FAN1/WP)
(see p.1, No. 4)

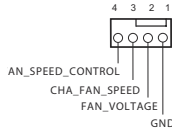

(4-pin CHA_FAN2/WP)
(see p.1, No. 13)

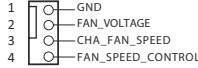

This motherboard provides two 4-Pin water cooling chassis fan connector. If you plan to connect a 3-Pin chassis water cooler fan, please connect it to Pin 1-3.

CPU Fan Connector
(4-pin CPU_FAN1)
(see p.1, No. 1)

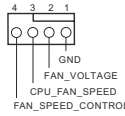

This motherboard provides a 4-Pin CPU fan (Quiet Fan) connector. If you plan to connect a 3-Pin CPU fan, please connect it to Pin 1-3.

ATX Power Connector
(24-pin ATXPWR1)
(see p.1, No. 6)

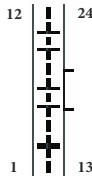

This motherboard provides a 24-pin ATX power connector. To use a 20-pin ATX power supply, please plug it along Pin 1 and Pin 13.

ATX 12V Power Connector
(8-pin ATX12V1)
(see p.1, No. 16)

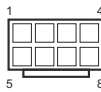

This motherboard provides a 8-pin ATX 12V power connector. To use a 4-pin ATX power supply, please plug it along Pin 1 and Pin 5.

***Warning: Please make sure that the power cable connected is for the CPU and not the graphics card. Do not plug the PCIe power cable to this connector.**

RGB LED Header
(4-pin RGB_LED1)
(see p.1, No. 3)



RGB header is used to connect RGB LED extension cable which allows users to choose from various LED lighting effects.

Caution: Never install the RGB LED cable in the wrong orientation; otherwise, the cable may be damaged.

* Please refer to page 35 for further instructions on this header.

Addressable LED Header
(3-pin ADDR_LED1)
(see p.1, No. 2)

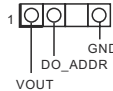

This header is used to connect Addressable LED extension cable which allows users to choose from various LED lighting effects.

Caution: Never install the Addressable LED cable in the wrong orientation; otherwise, the cable may be damaged.

* Please refer to page 36 for further instructions on this header.

2.7 M.2_SSD (NGFF) Module Installation Guide (M2_1)

The M.2, also known as the Next Generation Form Factor (NGFF), is a small size and versatile card edge connector that aims to replace mPCIe and mSATA. The Ultra M.2 Socket (M2_1) supports M Key type 2280 M.2 SATA3 6.0 Gb/s module and M.2 PCI Express module up to Gen3 x4 (32 Gb/s).

Installing the M.2_SSD (NGFF) Module

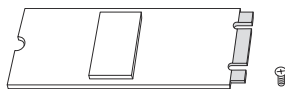

Step 1

Prepare a M.2_SSD (NGFF) module and the screw.

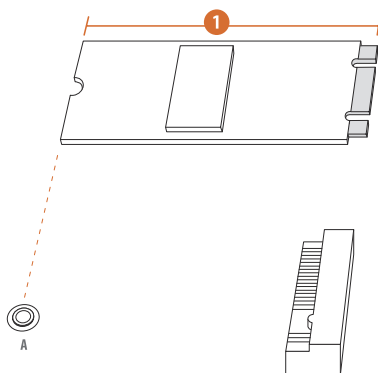

Step 2

Depending on the PCB type and length of your M.2_SSD (NGFF) module, find the corresponding nut location to be used.

No.	1
Nut Location	A
PCB Length	8cm
Module Type	Type 2280

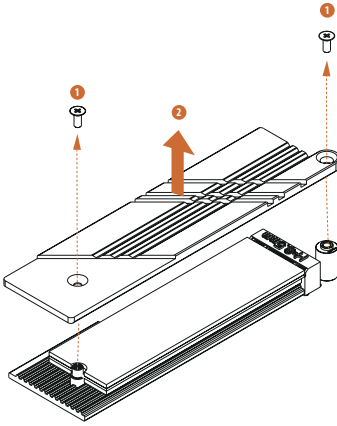

Step 3

Before installing a M.2 (NGFF) SSD module, please loosen the screws to remove the M.2 heatsink.

*Please remove the protective films on the bottom side of the M.2 heatsink before you install a M.2 SSD module.

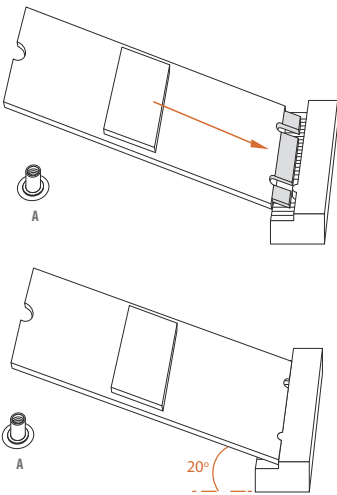

Step 4

Align and gently insert the M.2 (NGFF) SSD module into the M.2 slot. Please be aware that the M.2 (NGFF) SSD module only fits in one orientation.

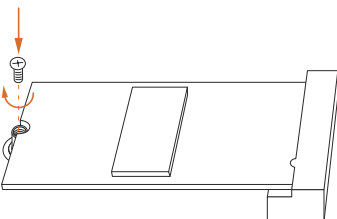

Step 5

Tighten the screw with a screwdriver to secure the module into place. Please do not overtighten the screw as this might damage the module.

M.2_SSD (NGFF) Module Support List

Vendor	Interface	P/N
ADATA	SATA3	AXNS330E-32GM-B
ADATA	SATA3	AXNS381E-128GM-B
ADATA	SATA3	AXNS381E-256GM-B
ADATA	SATA3	ASU800NS38-256GT-C
ADATA	SATA3	ASU800NS38-512GT-C
Crucial	SATA3	CT120M500SSD4
Crucial	SATA3	CT240M500SSD4
Intel	SATA3	Intel SSDSCKGW080A401/80G
Kingston	SATA3	SM2280S3
Plextor	PCIe	PX-G256M6e
Plextor	PCIe	PX-G512M6e
Samsung	PCIe x4	XP941-512G (MZHPU512HCGL)
SanDisk	PCIe	SD6PP4M-128G
SanDisk	PCIe	SD6PP4M-256G
Team	SATA3	TM4PS4128GMC105
Team	SATA3	TM4PS4256GMC105
Team	SATA3	TM8PS4128GMC105
Team	SATA3	TM8PS4256GMC105
Transcend	SATA3	TS256GMTS400
Transcend	SATA3	TS512GMTS600
Transcend	SATA3	TS512GMTS800
V-Color	SATA3	VLM100-120G-2280B-RD
V-Color	SATA3	VLM100-240G-2280RGB
V-Color	SATA3	VSM100-240G-2280
V-Color	SATA3	VLM100-240G-2280B-RD
WD	SATA3	WDS100T1B0B-00AS40
WD	SATA3	WDS240G1G0B-00RC30

For the latest updates of M.2_SSD (NFGG) module support list, please visit our website for details: <http://www.asrock.com>

2.8 ASRock Polychrome SYNC

ASRock Polychrome SYNC is a lighting control utility specifically designed for unique individuals with sophisticated tastes to build their own stylish colorful lighting system. Simply by connecting the LED strip, you can customize various lighting schemes and patterns, including Static, Breathing, Strobe, Cycling, Music, Wave and more.

Connecting the LED Strip

Connect your RGB LED strip to the **RGB LED Header (RGB_LED1)** on the motherboard.

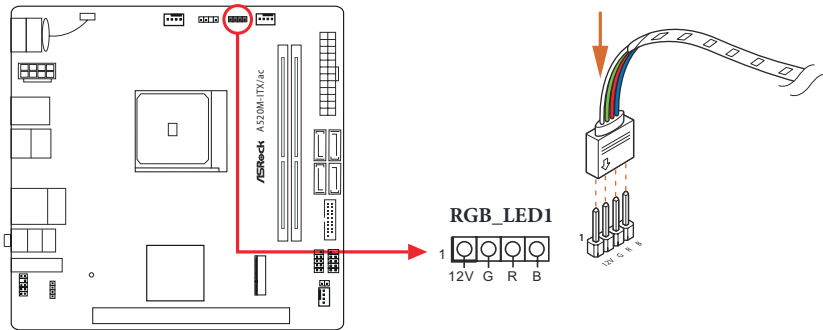

1. Never install the RGB LED cable in the wrong orientation; otherwise, the cable may be damaged.
2. Before installing or removing your RGB LED cable, please power off your system and unplug the power cord from the power supply. Failure to do so may cause damages to motherboard components.



1. Please note that the RGB LED strip do not come with the package.
2. The RGB LED header supports standard 5050 RGB LED strip (12V/G/R/B), with a maximum power rating of 3A (12V) and length within 2 meters.

Connecting the Addressable RGB LED Strip

Connect your Addressable RGB LED strip to the **Addressable LED Header (ADDR_LED1)** on the motherboard.

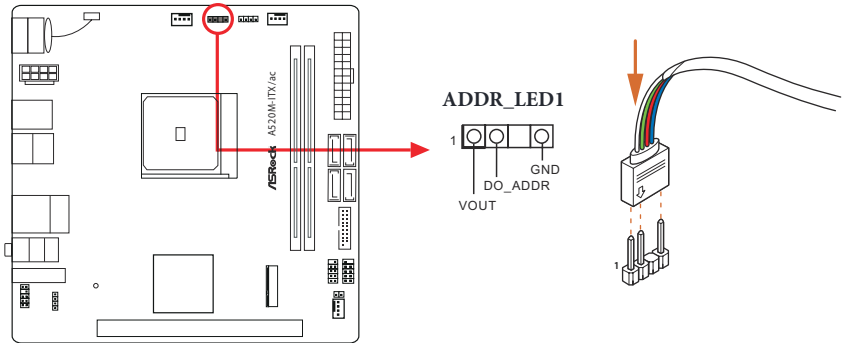

1. Never install the RGB LED cable in the wrong orientation; otherwise, the cable may be damaged.
2. Before installing or removing your RGB LED cable, please power off your system and unplug the power cord from the power supply. Failure to do so may cause damages to motherboard components.



1. Please note that the RGB LED strips do not come with the package.
2. The RGB LED header supports WS2812B addressable RGB LED strip (5V/Data/GND), with a maximum power rating of 3A (5V) and length within 2 meters.

ASRock Polychrome SYNC Utility

Now you can adjust the RGB LED color through the ASRock Polychrome SYNC Utility. Download this utility from the ASRock Live Update & APP Shop and start coloring your PC style your way!

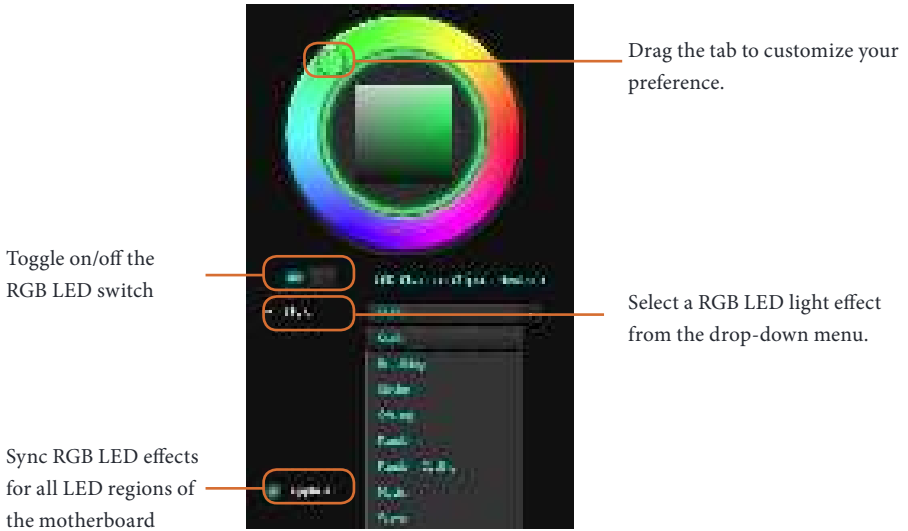

Technische Daten

- Plattform**
- Mini-ITX-Formfaktor
 - Feststoffkondensator-Design

- Prozessor**
- Unterstützt AMD AM4 Ryzen™ der 3. Generation / AMD Ryzen™-Prozessoren und höher (Prozessoren der 3000er- und 4000er-Serie)*
 - * Nicht kompatibel mit AMD Ryzen™ 5 3400G und Ryzen™ 3 3200G.
 - Digi Power design
 - 8-Leistungsphasendesign

- Chipsatz**
- AMD A520

- Speicher**
- Dualkanal-DDR4-Speichertechnologie
 - 2 x DDR4-DIMM-Steckplätze
 - Prozessoren der AMD-Ryzen-Serie (Matisse) unterstützen DDR4 4600+(OC)/4533(OC)/4466(OC)/4400(OC)/4333(OC)/4333(OC)/4266(OC)/4200(OC)/4133(OC)/4000(OC)/3866(OC)/3800(OC)/3733(OC)/3600(OC)/3466(OC)/3200/2933/2667/2400/2133 ECC und non-ECC, ungepufferter Speicher*
 - APUs (Renoir) der AMD-Ryzen-Serie unterstützen DDR4 4733+(OC)/4666(OC)/4600(OC)/4533(OC)/4466(OC)/4400(OC)/4333(OC)/4266(OC)/4200(OC)/4133(OC)/4000(OC)/3866(OC)/3800(OC)/3733(OC)/3600(OC)/3466(OC)/3200/2933/2667/2400/2133 ECC und non-ECC, ungepufferter Speicher*
 - * Weitere Informationen finden Sie in der Speicherkompatibilitätsliste auf der ASRock-Webseite. (<http://www.asrock.com/>)
 - * Bitte beachten Sie Seite 24 für die maximal unterstützte Frequenz von DDR4-UDIMM.
 - Systemspeicher, max. Kapazität: 64GB
 - Unterstützt Extreme-Memory-Profile- (XMP) Speichermodule
 - 15-µ-Goldkontakt in DIMM-Steckplätze

- Erweiterungssteckplatz**
- 1 x PCI-Express 3.0-x16-Steckplatz (PCIe1: x16-Modus)*
 - * Unterstützt PCIe-Riser-Karten zur Erweiterung auf x8/x8 Steckplätze
 - * Unterstützt NVMe-SSD als Bootplatte
 - 1 x vertikaler M.2-Sockel (Key E) mit dem mitgelieferten 802.11ac-WLAN-Modul (an den rückseitigen I/O)

Grafikkarte

- Integrierte Grafikkarte der AMD-Radeon™-Vega-Serie in APU der Ryzen-Serie*
- * Tatsächliche Unterstützung kann je nach Prozessor variieren
 - DirectX 12, Pixel Shader 5.0
 - Freigabespeicher von standardmäßig 2GB. Max. Freigabespeicher unterstützt bis zu 16GB.
- * Der max. Freigabespeicher von 16GB erfordert die Installation von 32GB Systemspeicher.
 - Dualer Grafikkartenausgang: Unterstützt HDMI- und DisplayPort 1.4-Ports durch unabhängige Monitor-Controller
 - Unterstützt HDMI 2.1 mit maximaler Auflösung von 4K x 2K (4096 x 2160) bei 60Hz
 - Unterstützt DisplayPort 1.4-Eingang mit maximaler Auflösung von bis zu 5K (5120 x 2880) bei 120 Hz
 - Unterstützt Auto-Lippensynchronizität, hohe Farbtiefe (12 bpc), xvYCC und HBR (Audio mit hoher Bitrate) mit HDMI 2.1-Port (konformer HDMI-Monitor erforderlich)
 - Unterstützt HDR (High Dynamic Range) mit HDMI 2.1
 - Unterstützt HDCP 2.3 mit HDMI 2.1- und DisplayPort 1.4-Ports
 - Unterstützt 4K-Ultra-HD- (UHD) Wiedergabe mit HDMI 2.1- und DisplayPort-1.4-Ports
 - Unterstützt Microsoft PlayReady®

Audio

- 7.1-Kanal-HD-Audio (Realtek ALC887-Audiocodec)
- Unterstützt Überspannungsschutz

LAN

- PCIE-x1-Gigabit-LAN 10/100/1000 Mb/s
- Realtek RTL8111H
- Unterstützt Wake-On-LAN
- Unterstützt Schutz gegen Blitzschlag/elektrostatische Entladung
- Unterstützt energieeffizientes Ethernet 802.3az
- Unterstützt PXE

Wireless**LAN**

- Intel®-802.11ac-WLAN-Modul
- Unterstützt IEEE 802.11a/b/g/n/ac
- Unterstützt Dualband (2,4/5 GHz)
- Unterstützt drahtlose Hochgeschwindigkeitsverbindungen bis 433 Mb/s
- Unterstützt Bluetooth 4.2 + High-Speed, Klasse II

Rückblende, E/A

- 2 x Antennenanschluss
- 1 x PS/2-Maus-/Tastaturanschluss
- 1 x HDMI-Port
- 1 x DisplayPort 1.4
- 2 x USB-2.0-Ports (unterstützt Schutz gegen elektrostatische Entladung)
- 3 x USB-3.2 Gen1-Typ-A-Port (unterstützt Schutz gegen elektrostatische Entladung)
- 1 x USB-3.2 Gen1-Typ-C-Port (unterstützt Schutz gegen elektrostatische Entladung)
- 1 x RJ-45-LAN-Port mit LED (Aktivität/Verbindung-LED und Geschwindigkeit-LED)
- HD-Audioanschlüsse: Line-in / Vorderer Lautsprecher / Mikrofon

Speicher

- 4 x SATA-III-6,0-Gb/s-Anschlüsse, unterstützt RAID (RAID 0, RAID 1 und RAID 10), NCQ, AHCI und Hot-Plugging
- 1 x Ultra-M.2-Sockel (M2_1), unterstützt M-Key-Typ-2280-M.2-SATA-III-6,0-Gb/s-Modul und M.2-PCI Express-Modul bis Gen3 x 4 (32 Gb/s)*

* Unterstützt NVMe-SSD als Bootplatte

* Unterstützt ASRock U.2-Kit

Anschluss

- 1 x RGB-LED-Stiflleiste
- * Unterstützt insgesamt bis zu 12 V/3 A, 36-W-LED-Streifen
- 1 x Adressierbare-LED-Stiflleiste
- * Unterstützt insgesamt bis zu 5 V/3 A, 15-W-LED-Streifen
- 1 x CPU-Lüfteranschluss (4-polig)
- * Der CPU-Lüfteranschluss unterstützt einen CPU-Lüfter mit einer maximalen Lüfterleistung von 1 A (12 W).
- 2 x Anschlüsse für Gehäuse-/Wasserpumpenlüfter (4-polig) (intelligente Lüftergeschwindigkeitssteuerung)
- * Der Gehäuse-/Wasserpumpenlüfter unterstützt einen Wasserkühlerlüfter mit einer maximalen Lüfterleistung von 2 A (24 W).
- * CHA_FAN1/WP und CHA_FAN2/WP können automatisch erkennen, ob ein 3- oder 4-poliger Lüfter verwendet wird.
- 1 x 24-poliger ATX-Netzanschluss
- 1 x 8-poliger 12-V-Netzanschluss
- 1 x Audioanschluss an Frontblende

- 1 x USB 2.0-Stiftleiste (unterstützt zwei USB 2.0-Ports)
(unterstützt Schutz gegen elektrostatische Entladung)
- 1 x USB 3.2 Gen1-Stiftleiste (unterstützt zwei USB 3.2 Gen1-Ports)
(unterstützt Schutz gegen elektrostatische Entladung)

BIOS- Funktion

- AMI-UEFI-Legal-BIOS mit Unterstützung grafischer Benutzerschnittstellen
- Unterstützt „Plug-and-Play“
- ACPI 5.1-konforme Aufweckereignisse
- Unterstützt Jumper-frei
- SMBIOS 2.3-Unterstützung
- CPU, CPU VDDCR_SOC, DRAM, VPPM, +1,8VSB, VDDP Mehrfachspannungsanpassung

Hardware- überwa- chung

- Temperaturerkennung: CPU-, Gehäuse-/Wasserpumpen-Lüfter
- Lüftertachometer: CPU-, Gehäuse-/Wasserpumpen-Lüfter
- Lautloser Lüfter (automatische Anpassung der Gehäuselüftergeschwindigkeit durch CPU-Temperatur): CPU-, Gehäuse-/Wasserpumpen-Lüfter
- Mehrfachgeschwindigkeitssteuerung: CPU-, Gehäuse-/Wasserpumpen-Lüfter
- Spannungsüberwachung: +12 V, +5 V, +3,3 V, CPU Vcore

Betriebs- system

- Microsoft® Windows® 10, 64 Bit

Zertifi- zierungen

- FCC, CE
- ErP/EuP ready (ErP/EuP ready-Netzteil erforderlich)

Spécifications

- Plateforme**
- Facteur de forme Mini-ITX
 - Conception à condensateurs solides

- Processeur**
- Prend en charge la 3^{ème} AMD AM4 Ryzen™ / AMD Ryzen™ prochaine génération (processeurs séries 3000 et 4000)*
 - * Non compatible avec AMD Ryzen™ 5 3400G et Ryzen™ 3 3200G.
 - Digi Power design
 - Alimentation à 8 phases

- Chipset**
- AMD A520

- Mémoire**
- Technologie mémoire double canal DDR4
 - 2 x fentes DIMM DDR4
 - Les Processeurs AMD série Ryzen (Matisse) prennent en charge les mémoires sans tampon ECC et non ECC DDR4 4600+(OC)/4533(OC)/4466(OC)/4400(OC)/4333(OC)/4333(OC)/4266(OC)/4200(OC)/4133(OC)/4000(OC)/3866(OC)/3800(OC)/3733(OC)/3600(OC)/3466(OC)/3200/2933/2667/2400/2133*
 - Les APU AMD série Ryzen (Renoir) prennent en charge les mémoires sans tampon ECC et non ECC DDR4 4733+(OC)/4666(OC)/4600(OC)/4533(OC)/4466(OC)/4400(OC)/4333(OC)/4266(OC)/4200(OC)/4133(OC)/4000(OC)/3866(OC)/3800(OC)/3733(OC)/3600(OC)/3466(OC)/3200/2933/2667/2400/2133*

* Veuillez consulter la liste de prise en charge des mémoires sur le site Web d'ASRock pour de plus amples informations.
(<http://www.asrock.com/>)

* Veuillez consulter la page 24 pour connaître la prise en charge de la fréquence maximale de l'UDIMM DDR4.

- Capacité max. de la mémoire système : 64 Go
- Prend en charge les modules mémoire Extreme Memory Profile (XMP)
- Contacts dorés 15µ sur fentes DIMM

- Fente d'expansion**
- 1 x fente PCI Express 3.0 x 16 (PCI-E1 : mode x16)*
 - * Prend en charge les cartes évolutives PCIe pour une extension x8/x8 emplacements
 - * Prend en charge les SSD NVMe comme disques de démarrage
 - 1 x socket M.2 vertical (touche E) avec le module Wi-Fi 802.11ac fourni (sur l'E/S arrière)

- Graphiques**
- Carte graphique AMD Radeon™ série Vega intégrée dans APU série Ryzen*
 - * La prise en charge réelle peut varier selon le processeur
 - DirectX 12, Pixel Shader 5.0
 - Mémoire partagée par défaut 2 Go. Mémoire partagée maximum prise en charge 16 Go.
 - * La mémoire partagée maximum de 16 Go nécessite 32 Go de mémoire système installée.
 - Double sortie graphique : Prend en charge les ports HDMI et DisplayPort 1.4 via contrôleurs d'affichage indépendants
 - Prend en charge la technologie HDMI 2.1 avec résolution maximale de 4K x 2K (4096x2160) @ 60 Hz
 - Prend en entrée DisplayPort 1.4 avec résolution maximale jusqu'à 5K (5120x2880) à 120 Hz
 - Prend en charge les technologies Auto Lip Sync, Deep Color (12bpc), xvYCC et HBR (High Bit Rate Audio) avec port HDMI 2.1 (un écran compatible HDMI est requis)
 - Prend en charge HDR (Plage dynamique étendue) avec HDMI 2.1
 - Prend en charge HDCP 2.3 via ports HDMI 2.1 et DisplayPort 1.4
 - Prend en charge la lecture 4K Ultra HD (UHD) avec les ports HDMI 2.1 et DisplayPort 1.4
 - Prend en charge Microsoft PlayReady®

- Audio**
- Audio 7.1 CH HD (Codec audio Realtek ALC887)
 - Prend en charge la protection contre les surtensions

- Réseau**
- PCIe x1 Gigabit LAN 10/100/1000 Mo/s
 - Realtek RTL8111H
 - Prend en charge la fonction Wake-On-LAN
 - Prend en charge la protection contre la foudre/les décharges électrostatiques
 - Prend en charge la fonction d'économie d'énergie Ethernet 802.3az
 - Prend en charge PXE

Réseau sans-fil

- Module Wi-Fi 802.11ac Intel®
- Prend en charge IEEE 802.11a/b/g/n/ac
- Prend en charge le mode Dual-Band (2,4/5 GHz)
- Prend en charge la connexion sans-fil à haute vitesse jusqu'à 433Mbps
- Prend en charge Bluetooth 4.2 + haute vitesse classe II

Connectique du panneau arrière

- 2 x ports antenne
- 1 x port souris/clavier PS/2
- 1 x port HDMI
- 1 x DisplayPort 1.4
- 2 x ports USB 2.0 (Protection contre les décharges électrostatiques)
- 3 x port USB 3.2 Gen1 type A (Protection contre les décharges électrostatiques)
- 1 x port USB 3.2 Gen1 type C (Protection contre les décharges électrostatiques)
- 1 x port RJ-45 LAN avec LED (LED ACT/LIEN et LED VITESSE)
- Connecteurs jack audio HD : Entrée ligne / haut-parleur avant / microphone

Stockage

- 4 x connecteurs SATA3 6,0 Go/s, prise en charge de RAID (RAID 0, RAID 1 et RAID 10), NCQ, AHCI et branchement à chaud
 - 1 x socket Ultra M.2 (M2_1), prend en charge les modules M.2 SATA3 6,0 Go/s type 2280 touche M et M.2 PCI Express jusqu'à Gen3 x4 (32 Go/s)*
- * Prend en charge les SSD NVMe comme disques de démarrage
* Prend en charge le kit ASRock U.2

Connecteur

- 1 x embase LED RVB
- * Prend en charge les rubans DEL jusqu'à 12 V/3 A, 36 W au total
- 1 x embase LED adressable
- * Prend en charge les rubans LED jusqu'à 5 V/3 A, 15 W au total
- 1 x connecteur pour ventilateur de CPU (4 broches)
- * Le connecteur pour ventilateur de CPU prend en charge un ventilateur de CPU d'une puissance maximale de 1 A (12 W).

- 2 x connecteurs pour ventilateur de châssis /pompe à eau (4 broches) (contrôle de vitesse de ventilateur intelligent)
- * Le ventilateur de châssis /pompe à eau prend en charge un ventilateur de refroidisseur d'eau d'une puissance maximale de 2 A (24 W).
- * CHA_FAN1/WP et CHA_FAN2/WP peuvent détecter automatiquement si un ventilateur 3 broches ou 4 broches est utilisé.
 - 1 x connecteur d'alimentation ATX 24 broches
 - 1 x connecteur d'alimentation 12 V 8 broches
 - 1 x connecteur audio panneau frontal
 - 1 x embase USB 2.0 (2 ports USB 2.0 pris en charge) (Protection contre les décharges électrostatiques)
 - 1 x embase USB 3.2 Gen1 (2 ports USB 3.2 Gen1 pris en charge) (Protection contre les décharges électrostatiques)

Caractéristiques du BIOS

- BIOS UEFI AMI avec prise en charge d'interface graphique
- Prend en charge la fonction « Plug and Play »
- Compatible ACPI 5.1 Wake Up Events
- Prend en charge la configuration Jumpfree
- Compatible SMBIOS 2.3
- Réglage de la tension CPU, CPU VDDCR_SOC, DRAM, VPPM, +1,8VSB, VDDP

Surveillance du matériel

- Détection de température : Ventilateurs de CPU / châssis / pompe à eau
- Tachymètre de ventilateur : Ventilateurs de CPU / châssis / pompe à eau
- Ventilateur silencieux (réglage automatique de la vitesse du ventilateur du châssis d'après la température du CPU) : Ventilateurs de CPU / châssis / pompe à eau
- Contrôle simultané des vitesses du ventilateur : Ventilateurs de CPU / châssis / pompe à eau
- Surveillance de la tension d'alimentation : +12V, +5V, +3,3V, CPU Vcore

Système d'exploitation

- Microsoft® Windows® 10 64 bits

Certifications

- FCC, CE
- ErP/EuP Ready (alimentation ErP/EuP ready requise)

Specifiche

- Piattaforma**
- Fattore di forma Mini-ITX
 - Design condensatore solido

- CPU**
- Supporta AMD AM4 Ryzen™/AMD Ryzen™ di terza generazione e successive generazioni (processori serie 3000 e 4000) *
- * Non compatibile con AMD Ryzen™ 5 3400G e Ryzen™ 3 3200G.
- Digi Power design
 - Potenza a 8 fasi

- Chipset**
- AMD A520

- Memoria**
- Tecnologia memoria DDR4 Dual Channel
 - 2 x alloggi DIMM DDR4
 - Le CPU serie AMD Ryzen (Matisse) supportano DDR4 4600+(OC)/4533(OC)/4466(OC)/4400(OC)/4333(OC)/4333(OC)/4266(OC)/4200(OC)/4133(OC)/4000(OC)/3866(OC)/3800(OC)/3733(OC)/3600(OC)/3466(OC)/3200/2933/2667/2400/2133 ECC e non ECC, senza buffer*
 - Le APU AMD Ryzen (Renoir) supportano DDR4 4733+(OC)/4666(OC)/4600(OC)/4533(OC)/4466(OC)/4400(OC)/4333(OC)/4266(OC)/4200(OC)/4133(OC)/4000(OC)/3866(OC)/3800(OC)/3733(OC)/3600(OC)/3466(OC)/3200/2933/2667/2400/2133 ECC e non ECC, senza buffer*
- * Per maggiori informazioni fare riferimento all'elenco dei supporti di memoria sul sito di ASRock. (<http://www.asrock.com/>)
- * Fare riferimento a pagina 24 per il supporto della frequenza massima DDR4 UDIMM.
- Capacità max. della memoria di sistema: 64GB
 - Supporta moduli di memoria Extreme Memory Profile (XMP)
 - Contatti d'oro 15µ negli alloggi DIMM

Alloggio d'espansione

- 1 x alloggiamento PCI Express 3.0 x16 (PCIe1: modalità x16)*
- * Supporta schede riser PCIe per estendere gli slot x8/x8
- * Supporto di SSD NVMe come disco d'avvio
- 1 x Socket M.2 verticale (Key E) con il modulo WiFi-802.11ac fornito (sul pannello I/O posteriore)

Grafica

- Grafica AMD Radeon™ serie Vega integrata nelle APU serie Ryzen*
- * Il supporto effettivo può variare in base alla CPU
- DirectX 12, Pixel Shader 5.0
- Memoria condivisa predefinita 2GB. Memoria condivisa massima supportata fino a 16GB.
- * La memoria condivisa massima di 16GB richiede che sia installata una memoria di sistema da 32GB.
- Doppia uscita grafica: supporto di porte HDMI e DisplayPort 1.4 tramite controller display indipendenti
- Supporta HDMI 2.1 con risoluzione massima fino a 4K x 2K (4096 x 2160) a 60 Hz
- Supporta ingresso DisplayPort 1.4 con risoluzione massima fino a 5K (5120 x 2880) a 120 Hz
- Supporto delle funzioni Auto Lip Sync, Deep Color (12bpc), xvYCC e HBR (High Bit Rate Audio) con porta HDMI 2.1 (è necessario un monitor compatibile HDMI)
- Supporta HDR (High Dynamic Range) con HDMI 2.1
- Supporto HDCP 2.3 con le porte HDMI 2.1 e DisplayPort 1.4
- Supporto riproduzione 4K Ultra HD (UHD) sulle porte HDMI 2.1 e DisplayPort 1.4
- Supporto Microsoft PlayReady®

Audio

- Audio HD 7.1 CH (codec audio Realtek ALC887)
- Supporta protezione da sovratensione

LAN

- 1 x PCIE LAN Gigabit 10/100/1000 Mb/s
- Realtek RTL8111H
- Supporto WOL (Wake-On-LAN)
- Supporta protezione da fulmini/scariche elettrostatiche
- Supporto Energy Efficient Ethernet 802.3az
- Supporto PXE

LAN wireless

- Modulo Intel® 802.11ac WiFi
- Supporta IEEE 802.11a/b/g/n/ac
- Supporta Dual-Band (2,4/5 GHz)
- Supporta la connessione wireless ad alta velocità fino a 433 Mbps
- Supporto di Bluetooth 4.2 + High speed Classe II

I/O pannello posteriore

- 2 x porte antenna
- 1 x porta mouse/tastiera PS/2
- 1 x porta HDMI
- 1 x DisplayPort 1.4
- 2 x porte USB 2.0 (supporto protezione da scariche elettrostatiche)
- 3 x Porta USB 3.2 Gen1 di tipo A (supporta protezione da scariche elettrostatiche)
- 1 x Porta USB 3.2 Gen1 di tipo C (supporta protezione da scariche elettrostatiche)
- 1 x porta LAN RJ-45 con LED (ACT/LINK LED e SPEED LED)
- Connettori audio HD: Ingresso linea / altoparlante frontale / microfono

Archiviazione

- 4 x connettori SATA3 6,0 Gb/s, supporto RAID (RAID 0, RAID 1, e RAID 10), NCQ, AHCI e Hot Plug
- 1 x socket Ultra M.2 (M2_1), supporta il modulo M.2 SATA3 6,0 Gb/s di tipo M Key 2280 ed il modulo M.2 PCI Express fino a Gen3 x4 (32 Gb/s)*
- * Supporto di SSD NVMe come disco d'avvio
- * Supporta kit ASRock U.2

Connettore

- 1 x collettore LED RGB
- * Supporto totale di fino a 12V/3A, 36W strip LED
- 1 x Header LED indirizzabile
- * Supporto totale di fino a 5V/3A, 15W strip LED
- 1 x connettore ventola CPU (4-pin)
- * Il connettore ventola CPU supporta ventole CPU con potenza massima di 1 A (12 W).

- 2 x connettori ventola telaio/ventola pompa dell'acqua (4-pin)
(Controllo intelligente della velocità della ventola)
- * La ventola Chassis/ventola pompa dell'acqua supporta ventole di sistemi di raffreddamento ad acqua di potenza massima di 2 A (24W).
- * CHA_FAN1/WP e CHA_FAN2/WP sono in grado di rilevare se è in uso una ventola a 3 pin o 4 a pin.
- 1 x connettore alimentazione ATX 24-pin
- 1 x connettore alimentazione 12 V 8-pin
- 1 x connettore audio pannello frontale
- 1 x connettore USB 2.0 (supporto di 2 porte USB 2.0) (supporto protezione da scariche elettrostatiche)
- 1 x connettore USB 3.2 Gen1 (supporto di 2 porte USB 3.2 Gen1) (supporto protezione da scariche elettrostatiche)

Funzionalità BIOS

- AMI UEFI Legal BIOS con interfaccia di supporto
- Supporta "Plug and Play"
- Eventi di riattivazione conformi a ACPI 5.1
- Supporta jumperfree
- Supporto di SMBIOS 2.3
- Regolazione variabile tensione CPU, CPU VDDCR_SOC, DRAM, VPPM, +1,8VSB, VDDP

Hardware Monitor

- Sensore di temperatura: Ventole CPU, chassis, pompa dell'acqua
- Tachimetro ventola: Ventole CPU, chassis, pompa dell'acqua
- Ventola silenziosa (regolazione automatica velocità in base alla temperatura della CPU): Ventole CPU, chassis, pompa dell'acqua
- Controllo velocità ventola: Ventole CPU, chassis, pompa dell'acqua
- Monitoraggio tensione: +12 V, +5 V, +3,3 V, CPU Vcore

SO

- Microsoft® Windows® 10 64 bit

Certificazioni

- FCC, CE
- ErP/EuP Ready (è necessaria alimentazione ErP/EuP ready)

Especificaciones

- Plataforma**
- Factor de forma Mini-ITX
 - Diseño de condensador sólido

- CPU**
- Admite AMD AM4 Ryzen™ / Ryzen™ de 3ª generación y posteriores Procesadores (Procesadores de las Series 3000 y 4000)*
 - * No es compatible con AMD Ryzen™ 5 3400G o Ryzen™ 3 3200G.
 - Digi Power design
 - Diseño de 8 fases de alimentación

- Conjunto de chips**
- AMD A520

- Memoria**
- Tecnología de memoria DDR4 de doble canal
 - 2 x ranuras DIMM DDR4
 - Las CPU de la serie AMD Ryzen (Matisse) admiten memoria sin búfer DDR4 4600+(OC)/4533(OC)/4466(OC)/4400(OC)/4333(OC)/4333(OC)/4266(OC)/4200(OC)/4133(OC)/4000(OC)/3866(OC)/3800(OC)/3733(OC)/3600(OC)/3466(OC)/3200/2933/2667/2400/2133 ECC y no ECC*
 - Las APU de la serie AMD Ryzen (Renoir) admiten memoria sin búfer DDR4 4733+(OC)/4666(OC)/4600(OC)/4533(OC)/4466(OC)/4400(OC)/4333(OC)/4266(OC)/4200(OC)/4133(OC)/4000(OC)/3866(OC)/3800(OC)/3733(OC)/3600(OC)/3466(OC)/3200/2933/2667/2400/2133 ECC y no ECC*
 - * Para obtener más información, consulte la lista de memorias compatibles en el sitio web de ASRock. (<http://www.asrock.com/>)
 - * Consulte la página 24 para conocer las frecuencias máximas compatibles de DDR4 UDIMM.
 - Capacidad máxima de memoria del sistema: 64GB
 - Admite módulos de memoria Extreme Memory Profile (XMP)
 - Contacto 15µ Gold en ranuras DIMM

- Ranura de expansión**
- 1 x ranura PCI Express 3.0 x16 (PCIe1: modo x16)*
 - * Admite tarjetas verticales PCIe para extender ranuras x8/x8
 - * Admite unidad de estado sólido de NVMe como disco de arranque
 - 1 x Zócalo M.2 vertical (clave E) con el módulo WiFi-802.11ac integrado (en la E/S trasera)

Gráficos

- Tarjeta gráfica de la serie AMD Radeon™ Vega integrada en APU de la serie Ryzen*
- * El soporte real puede variar según la CPU
- DirectX 12, Pixel Shader 5.0
- Memoria compartida predeterminada de 2 GB. Memoria máxima compartida admite hasta 16 GB.
- * La memoria compartida máxima de 16GB requiere que haya una memoria del sistema de 32 GB instalada.
- Salida gráfica dual: compatible con puertos HDMI y DisplayPort 1.4 mediante controladores de pantalla independientes
- Compatible con HDMI 2.1 con una resolución máxima de 4K x 2K (4096x2160) a 60Hz
- Compatible con entrada de DisplayPort 1.4 con una resolución máxima de hasta 5K (5120x2880) a 120Hz
- Admite Sincronización automática entre audio y vídeo, color profundo (12 bpc), xvYCC y HBR (audio de alta tasa de bits) con puerto HDMI 2.1 (se necesita un monitor compatible con HDMI)
- Admite HDR (alto rango dinámico) con HDMI 2.1
- Compatible con HDCP 2.3 con puertos HDMI 2.1 y DisplayPort 1.4
- Admite reproducción 4K Ultra HD (UHD) con los puertos HDMI 2.1 y DisplayPort 1.4
- Compatible con Microsoft PlayReady®

Audio

- 7.1 Audio CH HD (Código de audio Realtek ALC887)
- Admite protección contra sobretensiones

LAN

- PCIE x1 Gigabit LAN 10/100/1000 Mb/s
- Realtek RTL8111H
- Admite la función Reactivación de LAN
- Admite protección contra rayos y descargas electrostáticas (ESD)
- Admite Ethernet 802.3az de eficiencia energética
- Admite PXE

LAN**inalámbrica**

- Módulo WiFi Intel® 802.11ac
- Compatible con IEEE 802.11a/b/g/n/ac
- Compatible con Banda Dual (2,4/5 GHz)
- Compatible con conexión inalámbrica de alta velocidad hasta 433 Mbps
- Compatible con Bluetooth 4.2+ Alta velocidad clase II

E/S en panel posterior

- 2 x Puertos de antena
- 1 x puerto de ratón/teclado PS/2
- 1 x puerto HDMI
- 1 x DisplayPort 1.4
- 2 x Puertos USB 2.0 (admite protección contra descargas electrostáticas)
- 3 x Puerto USB 3.2 Gen1 de tipo A (admite protección contra descargas electrostáticas)
- 1 x Puerto USB 3.2 Gen1 de tipo C (admite protección contra descargas electrostáticas)
- 1 x Puerto LAN RJ-45 con LED (LED DE ACTIVIDAD/ENLACE y LED DE VELOCIDAD)
- Conector de audio HD: Entrada de línea / Altavoz frontal / Micrófono

Almacenamiento

- 4 x conectores SATA3 de 6,0 Gb/s, compatible con RAID (RAID 0, RAID 1 y RAID 10), NCQ, AHCI y conexión en caliente
 - 1 x Zócalo Ultra que admite el módulo SATA3 6,0 Gb/s M.2 (M2_1) de tipo 2280 con clave M y el módulo PCI Express M.2 hasta Gen3 x4 (32 Gb/s)*
- * Admite unidad de estado sólido de NVMe como disco de arranque
- * Admite el Kit U.2 de ASRock

Conector

- 1 x Cabezal de indicador LED RGB
- * Admite una tira de LED de hasta 12 V/3 A (36 W) en total
- 1 x Base de conexiones de LED direccionable
- * Admite una tira de LED de hasta 5 V/3 A (15 W) en total
- 1 x Conector para ventilador de la CPU (4 contactos)
- * El conector para ventilador de la CPU admite ventilador de la CPU con una potencia de ventilador de 1 A (12 W) máxima.
- 2 x Conectores (4 contactos) para el ventilador de la bomba de agua/chasis (control de velocidad de ventilador inteligente)
- * El ventilador de la bomba de agua/Chasis admite ventilador del disipador por agua con una potencia de ventilador máxima de 2 A (24 W).
- * CHA_FAN1/WP y CHA_FAN2/WP se pueden detectar automáticamente si se usa el ventilador de 3 o 4 contactos.
- 1 x conector de alimentación ATX de 24 contactos
 - 1 x conector de alimentación de 12V de 8 contactos

- 1 x Conector de audio en el panel frontal
- 1 x Base de conexiones USB 2.0 (admite 2 puertos USB 2.0).
Admite protección contra descargas electrostáticas.
- 1 x base de conexiones USB 3.2 Gen1 (Admite 2 puertos USB 3.2 Gen1) (Admite protección contra descargas electrostáticas)

Función de la BIOS

- BIOS legal UEFI AMI compatible con interfaz gráfica de usuario
- Compatible con “Plug and Play”
- Eventos de reactivación conformes con ACPI 5.1
- Compatible con Jumper FREE
- Admite SMBIOS 2.3
- Multi-ajuste de voltaje de CPU, CPU VDDCR_SOC, DRAM, VPPM, +1,8VSB, VDDP

Monitor de hardware

- Detección de temperatura: Ventiladores de la bomba de agua/chasis/CPU
- Tacómetro del ventilador: Ventiladores de la bomba de agua/chasis/CPU
- Ventilador silencioso (ajuste automático de la velocidad del ventilador del chasis por temperatura de la CPU): Ventiladores de la bomba de agua/chasis/CPU
- Control de varias velocidades del ventilador: Ventiladores de la bomba de agua/chasis/CPU
- Supervisión del voltaje: +12 V, +5 V, +3,3 V, Vcore de CPU

SO

- Microsoft® Windows® 10 64 bits

Certificaciones

- FCC y CE
- Preparado para ErP/EuP (se necesita una fuente de alimentación preparada para ErP/EuP)

Технические характеристики

Платформа

- Форм-фактор Mini-ITX
- Схема на основе твердотельных конденсаторов

ЦП

- Поддержка процессоров AMD AM4 Ryzen™ / AMD Ryzen™ 3-го и будущих поколений (процессоры серии 3000 и 4000)*
- * Несовместимо с процессорами AMD Ryzen™ 5 3400G и Ryzen™ 3 3200G
- Digi Power design
- Система питания 8

Чипсет

- AMD A520

Память

- Двухканальная память DDR4
- 2 гнезда DDR4 DIMM
- ЦП серии AMD Ryzen (Matisse) поддерживают модули памяти DDR4 4600+(OC)/4533(OC)/4466(OC)/4400(OC)/4333(OC)/4333(OC)/4266(OC)/4200(OC)/4133(OC)/4000(OC)/3866(OC)/3800(OC)/3733(OC)/3600(OC)/3466(OC)/3200/2933/2667/2400/2133 с ECC и без ECC, небуферизованной памяти*
- Гибридные процессоры AMD серии Ryzen (Renoir) поддерживают модули памяти DDR4 4733+(OC)/4666(OC)/4600(OC)/4533(OC)/4466(OC)/4400(OC)/4333(OC)/4266(OC)/4200(OC)/4133(OC)/4000(OC)/3866(OC)/3800(OC)/3733(OC)/3600(OC)/3466(OC)/3200/2933/2667/2400/2133 с ECC и без ECC, небуферизованной памяти*
- * Дополнительная информация представлена в Списке совместимой памяти (Memory Support List) на веб-сайте ASRock. (<http://www.asrock.com/>)
- * Максимальные поддерживаемые частоты DDR4 UDIMM см на стр. 24.
- Максимальный объем ОЗУ: 64 Гб
- Поддержка модулей памяти XMP (Extreme Memory Profile)
- Позолоченные (15 мкм) контакты слотов DIMM

Слоты расширения

- 1 слот PCI Express 3.0 x16 (PCIЕ1; режим x16)*
- * Поддержка райзер-карт PCIe для расширения слотов x8/x8
- * Поддерживаются в качестве загрузочных SSD-диски типа NVMe
- 1 вертикальный слот M.2 (ключ E) с входящим в комплект поставки модулем WiFi-802.11ac (на задней панели ввода-вывода)

Графическая подсистема

- Встроенный видеоадаптер AMD Radeon™ серии Vega в процессорах APU серии Ryzen*
- *Фактическая поддержка зависит от процессора
- DirectX 12, пиксельные шейдеры 5.0
- Общий объем памяти по умолчанию 2 ГБ. Поддерживается максимальный общий объем памяти до 16 ГБ.
- * Для максимального общего объема памяти 16 ГБ требуется установить системную память емкостью 32 ГБ.
- Два графических выхода: поддержка портов HDMI и DisplayPort 1.4 независимыми контроллерами дисплея
- Поддержка HDMI 2.1 с максимальным разрешением до 4K × 2K (4096x2160) при 60 Гц
- Поддержка Вход DisplayPort 1.4 с максимальным разрешением до 5K (5120x2880) при частоте 120 Гц
- Поддерживаются Auto Lip Sync, Deep Color (12 бит/цвет), xvYCC и HBR (High Bit Rate Audio) через порт HDMI 2.1 (требуется соответствующий HDMI-монитор)
- Поддерживается расширенный динамический диапазон (HDR) в режиме HDMI 2.1
- Поддерживается функция HDCP 2.3 через порты HDMI 2.1 и DisplayPort 1.4
- Поддержка вывода видео с разрешением 4K Ultra HD (UHD) на порты HDMI 2.1 и DisplayPort 1.4
- Поддержка Microsoft PlayReady®

Звук

- 7.1-канальный звук высокой четкости (аудиокодек Realtek ALC887)
- Защита от перепадов напряжения в электрической сети

LAN

- PCIE x1 Gigabit LAN 10/100/1000 Мбит/с
- Realtek RTL8111H
- Поддерживается пробуждение по ЛВС
- Молниезащита и защита от электростатических разрядов
- Поддерживается Energy Efficient Ethernet 802.3az
- Поддерживается PXE

Беспроводная ЛВС

- Модуль WiFi Intel® 802.11ac
- Поддержка IEEE 802.11a/b/g/n/ac
- Поддержка двух диапазонов (2,4/5 ГГц)
- Поддержка высокоскоростного беспроводного подключения до 433 Мбит/с
- Поддержка Bluetooth 4.2 + High speed class II

Тыловые порты ввода-вывода

- 2 антенных порта
- 1 порт PS/2 для мыши/клавиатуры
- 1 порт HDMI
- 1 порт DisplayPort 1.4
- 2 порта USB 2.0 (с защитой от электростатических разрядов)
- 3 x Порт USB 3.2 Gen1 тип A (с защитой от электростатических разрядов)
- 1 x Порт USB 3.2 Gen1 тип C (с защитой от электростатических разрядов)
- 1 порт ЛВС RJ-45 с индикаторами («Активность/Соединение» и «Скорость»)
- Разъемы HD Audio: линейный вход / фронтальные AC / микрофон

Запоминающие устройства

- 4 x порта SATA3 со скоростью передачи данных 6,0 Гб/с, поддержка RAID (RAID 0, RAID 1 и RAID 10), NCQ, AHCI и «горячего подключения».
- 1 слот Ultra M.2 (M2_1), поддерживает модуль M.2 SATA3 типа 2280 со скоростью обмена данными 6,0 Гбит/с с ключом M и модуль M.2 PCI Express до версии Gen3 x4 (32 Гбит/с)*

* Поддерживаются в качестве загрузочных SSD-диски типа NVMe

* Поддерживается комплект ASRock U.2

Разъемы

- 1 колодка светодиодной RGB-подсветки
- * Поддерживается светодиодная лента (максимум 12 В/3 А, суммарной мощностью до 36 Вт).
- 1 колодка адресуемой светодиодной подсветки
- * Поддерживается светодиодная лента (максимум 5 В/3 А, суммарной мощностью до 15 Вт).
- 1 разъем для вентилятора охлаждения ЦП (4-контактный)
- * Разъем процессорного вентилятора поддерживает вентилятор с потребляемым током не более 1 А (12 Вт).
- 2 разъемы для корпусного вентилятора или водяной помпы (4-контактный) (смарт-регулятор скорости вентилятора)
- * Разъем для корпуса корпусного вентилятора или водяной помпы поддерживает вентилятор с потребляемым током не более 2 А (24 Вт).
- * Для разъемов CHA_FAN1/WP и CHA_FAN2/WP автоматически определяется тип подключенного вентилятора: 3- или 4-контактный.
- 1 разъем питания ATX, 24-контактный
- 1 разъем питания 12 В, 8-контактный
- 1 аудиоразъем для передней панели
- 1 колодка USB 2.0 (2 порта USB 2.0 с защитой от электростатических разрядов)
- 1 колодка USB 3.2 Gen1 (2 порта USB 3.2 Gen1) (с защитой от электростатических разрядов)

Параметры BIOS

- AMI UEFI Legal BIOS с поддержкой графического интерфейса
- Поддержка технологии «Plug and Play»
- Совместимость с управлением энергопотреблением по ACPI 5.1
- Поддержка функции JumperFree
- Поддерживается SMBIOS 2.3
- Регулировка напряжений CPU, CPU VDDCR_SOC, DRAM, VPPM, +1,8VSB, VDDP

Контроль оборудования

- Контроль температуры: вентилятор ЦП; корпусной вентилятор или помпа водяного охлаждения корпуса
- Тахометр: вентилятор ЦП; корпусной вентилятор или помпа водяного охлаждения корпуса
- Бесшумная работа (с автоматической регулировкой скорости вращения в зависимости от температуры ЦП): вентилятор ЦП; корпусной вентилятор или помпа водяного охлаждения корпуса
- Регулировка скорости вращения: вентилятор ЦП; корпусной вентилятор или помпа водяного охлаждения корпуса
- Контроль напряжений: +12 В, +5 В, +3,3 В, Vcore ЦП

Операционные системы

- Microsoft® Windows® 10 (64-разрядная)

Сертификация

- FCC, CE
- Совместимость с ErP/EuP (необходим блок питания, соответствующий стандарту ErP/EuP)

Especificações

- Plataforma**
- Formato Mini-ITX
 - Design de condensador sólido

- CPU**
- Suporta 3^ª Ger AMD AM4 Ryzen™ / Ryzen™ futuras gerações de Processadores (Processadores Série 3000 e 4000)*
 - * Não compatível com AMD Ryzen™ 5 3400G e Ryzen™ 3 3200G.
 - Digi Power design
 - Design com 8 fases de alimentação

- Chipset**
- AMD A520

- Memória**
- Tecnologia de memória DDR4 de dois canais
 - 2 x Slots DIMM DDR4
 - CPUs série AMD Ryzen (Matisse) suporta DDR4 4600+(OC)/4533(OC)/4466(OC)/4400(OC)/4333(OC)/4333(OC)/4266(OC)/4200(OC)/4133(OC)/4000(OC)/3866(OC)/3800(OC)/3733(OC)/3600(OC)/3466(OC)/3200/2933/2667/2400/2133 ECC & não-ECC, memória sem buffer*
 - AMD Ryzen série APUs (Renoir) suporta DDR4 4733+(OC)/4666(OC)/4600(OC)/4533(OC)/4466(OC)/4400(OC)/4333(OC)/4266(OC)/4200(OC)/4133(OC)/4000(OC)/3866(OC)/3800(OC)/3733(OC)/3600(OC)/3466(OC)/3200/2933/2667/2400/2133 ECC & não-ECC, memória sem buffer*
 - * Por favor, consulte a Lista de Suporte de Memória no site da ASRock para obter mais informação. (<http://www.asrock.com/>)
 - * Por favor consulte a página 24 para suporte de frequência máxima DDR4 UDIMM.
 - Capacidade máxima da memória do sistema: 64GB
 - Suporta módulos de memória Extreme Memory Profile (XMP)
 - Contato em Ouro 15µ nos slots DIMM

Slot de expansão

- 1 x Slot PCI Express 3.0 x16 (PCIe1: modo x16)*
- * Suporta placas riser de PCIe para estender slots x8/x8
- * Suporta NVMe SSD como discos de inicialização
- 1 x Soquete M.2 Vertical (Tecla E) com módulo Wi-Fi-802.11ac incluído (na I/O traseira)

Gráficos

- AMD Radeon™ Integrado Série Vega Gráficas na Série Ryzen APU*
- * Suporte atual pode variar por CPU
- DirectX 12, Pixel Shader 5.0
- Memória compartilhada padrão 2GB. Memória compartilhada máx suporta até 16GB.
- * A memória compartilhada máx de 16GB requer 32GB de memória de sistema instalado.
- Saída gráfica dupla: Suporta portas HDMI e DisplayPort 1.4 por controladores de vídeo independentes
- Suporta HDMI 2.1 com resolução máx. até 4K x 2K (4096x2160) @ 60Hz
- Suporta entrada de DisplayPort 1.4 com resolução máx. até 5K (5120x2880)@120Hz
- Suporta Auto sincronização labial, Deep Color (12bpc), xvYCC e HBR (High Bit Rate Audio) com porta HDMI 2.1 (É necessário um monitor compatível com HDMI)
- Suporta HDR (High Dynamic Range – Ampla Faixa Dinâmica) com HDMI 2.1
- Suporta HDCP 2.3 com Portas HDMI 2.1 e DisplayPort 1.4
- Suporta reprodução HD Ultra (UHD) 4K com portas HDMI 2.1 e DisplayPort 1.4
- Suporta Microsoft PlayReady®

Áudio

- Áudio 7.1 CH HD com proteção de conteúdo (Codec de áudio Realtek ALC887)
- Suporta Proteção de Sobretensão

- LAN**
- LAN Gigabit 10/100/1000 Mb/s PCIE x1
 - Realtek RTL8111H
 - Suporta Wake-On-LAN
 - Oferece Suporte à Proteção de Relâmpago/ESD
 - Suporta Energy Efficient Ethernet 802.3az
 - Suporta PXE

- LAN sem fios**
- Módulo Intel® 802.11ac WiFi (Pacote Gratuito)
 - Suporta IEEE 802.11a/b/g/n/ac
 - Suporta banda dupla (2,4/5 GHz)
 - Suporta conexão sem fio de alta velocidade até 433Mbps
 - Suporta Bluetooth 4.2 + Classe II de alta velocidade

- E/S do painel posterior**
- 2 x Portas de Antena
 - 1 x Porta PS/2 para mouse/teclado
 - 1 x Porta HDMI
 - 1 x DisplayPort 1.4
 - 2 x Portas USB 2.0 (Suporta Proteção ESD)
 - 3 x Porta USB 3.2 Gen1 Tipo A (Suporta Proteção ESD)
 - 1 x Porta USB 3.2 Gen1 Tipo C (Suporta Proteção ESD)
 - 1 x Porta LAN RJ-45 com LED (LED ACT/LINK e LED DE VELOCIDADE)
 - Fichas de áudio HD: Entrada de Linha / Autofalante Frontal / Microfone

- Armazenamento**
- 4 x Conectores SATA3 6,0 Gb/s, suporta RAID (RAID 0, RAID 1, e RAID 10), NCQ, AHCI e Conexão a Quente
 - 1 x soquete Ultra M.2 (M2_1), suporta M Key tipo módulo 2280 M.2 SATA3 6,0 Gb/s e módulo M.2 PCI Express até Gen3x4 (32 Gb/s)*
- * Suporta NVMe SSD nos discos de inicialização
* Suporta Kit U.2 ASRock

- Conector**
- 1 x Cabeçote de LED RGB
- * Suporta no total até 12V/3A, Tira de LED de 36W
- 1 x Plataforma de LED Ajustável
- * Suporta no total até 5V/3A, Tira de LED de 15W
- 1 x Conector da ventoinha da CPU (4 pinos)
- * O Conector do Ventilador de CPU suporta o ventilador de CPU de alimentação máxima 1A do ventilador (12W).

- 2 x Conectores de Ventilador de Chassi/Ventilador da Bomba de Água (4 pinos) (Controle de Velocidade de Ventoinha Inteligente)
- * O Ventilador de Chassi/Ventilador da Bomba de Água suporta o ventilador de refrigerador a água de 2A máximo (24W) potência do ventilador.
- * CHA_FAN1/WP e CHA_FAN2/WP podem detectar automaticamente se ventoinha de 3 pinos ou 4 pinos está em uso.
- 1 x Conector alimentação ATX 24-pinos
- 1 x Conector de energia 8-pinos 12V
- 1 x Conector de áudio do painel frontal
- 1 x Plataforma USB 2.0 (Suporta 2 portas USB 2.0) (Suporta Proteção ESD)
- 1 x Plataforma USB 3.2 Gen1 (Suporta 2 portas USB 3.2 Gen1) (Suporta Proteção ESD)

Funções da BIOS

- AMI UEFI Legal BIOS com suporte GUI
- Suporta “Plug and Play”
- ACPI 5.1 compatível com eventos de despertar
- Suporta jumperfree
- Suporte SMBIOS 2.3
- Multi-ajuste de tensão de CPU, CPU VDDCR_SOC, DRAM, VPPM, +1,8VSB, VDDP

Monitor de hardware

- Sensor de Temperatura: Ventilador da CPU, Chassis/Bomba de Água
- Tacômetro da ventoinha: Ventilador da CPU, Chassis/Bomba de Água
- Ventoinha Silenciosa (Auto ajusta velocidade da ventoinha do chassi pela temperatura da CPU): Ventilador da CPU, Chassis/Bomba de Água
- Controle multi-velocidade da ventoinha: Ventilador da CPU, Chassis/Bomba de Água
- Monitoramento da tensão: +12V, +5V, +3,3V, CPU Vcore

SO

- Microsoft® Windows® 10 64-bit

Certificações

- FCC, CE
- Preparada para ErP/EuP (é necessária uma fonte de alimentação preparada para ErP/EuP)

Specyfikacje

- Platforma**
- Współczynnik kształtu Mini-ITX
 - Konstrukcja kondensatorami stałymi

- CPU**
- Obsługa 3-ciej generacji procesorów AMD AM4 Ryzen™ / Ryzen™ z przyszłym procesorem (Procesory serii 3000 i 4000)*
 - * Brak zgodności z AMD Ryzen™ 5 3400G i Ryzen™ 3 3200G.
 - Digi Power design
 - Sekcja zasilania 8 Power Phase Design

- Chipset**
- AMD A520

- Pamięć**
- Technologia pamięci Dual Channel DDR4
 - 2 x gniazda DDR4 DIMM
 - Seria CPU AMD Ryzen (Matisse) z obsługą niebuforowanej pamięci DDR4 4600+(OC)/4533(OC)/4466(OC)/4400(OC)/4333(OC)/4333(OC)/4266(OC)/4200(OC)/4133(OC)/4000(OC)/3866(OC)/3800(OC)/3733(OC)/3600(OC)/3466(OC)/3200/2933/2667/2400/2133 ECC i nie-ECC*
 - Seria APU AMD Ryzen (Renoir) z obsługą niebuforowanej pamięci DDR4 4733+(OC)/4666(OC)/4600(OC)/4533(OC)/4466(OC)/4400(OC)/4333(OC)/4266(OC)/4200(OC)/4133(OC)/4000(OC)/3866(OC)/3800(OC)/3733(OC)/3600(OC)/3466(OC)/3200/2933/2667/2400/2133 ECC i nie-ECC*
 - * Sprawdź listę obsługiwanej pamięci na stronie internetowej ASRock w celu uzyskania dalszych informacji. (<http://www.asrock.com/>)
 - * Sprawdź stronę 24 w celu uzyskania informacji o maksymalnej obsługiwanej częstotliwości DDR4 UDIMM.
 - Maks. wielkość pamięci systemowej: 64GB
 - Obsługa modułów pamięci Extreme Memory Profile (XMP)
 - 15µ pozłacane styki w gniazdach DIMM

- Gniazdo rozszerzenia**
- 1 x gniazdo PCI Express 3.0 x 16 (tryb PCIe1:x16)*
 - * Obsługa kart riser PCIe w celu rozszerzenia do gniazd x8/x8
 - * Obsługa SSD NVMe, jako dysków rozruchowych
 - 1 x pionowe gniazdo M.2 (Key E) z wbudowanym modulem WiFi-802.11ac (z tyłu Wejścia/Wyjścia)

Grafika

- Zintegrowana karta graficzna AMD Radeon™ serii Vega w APU serii Ryzen*

* Rzeczywista obsługa zależy od CPU

- DirectX 12, Pixel Shader 5.0
- Pamięć współdzielona, domyślnie 2GB. Maksymalnie pamięć współdzielona obsługuje do 16GB.

* Maksymalna pamięć współdzielona 16GB wymaga zainstalowania 32GB pamięci systemowej.

- Podwójne wyjście graficzne: Obsługa HDMI i DisplayPort 1.4 przez niezależne sterowniki graficzne
- Obsługa HDMI 2.1 z maks. rozdzielczością do 4K x 2K (4096x2160) przy 60Hz
- Obsługa wejście DisplayPort 1.4 z maks. rozdzielczością do 5K (5120x2880) przy 120Hz
- Obsługa Auto Lip Sync, Deep Color (12bpc), xvYCC i HBR (High Bit Rate Audio) z portami HDMI 2.1 (Wymagany monitor zgodny z HDMI)
- Obsługa HDR (High Dynamic Range) z HDMI 2.1
- Obsługa portów HDCP 2.3 z HDMI 2.1 i DisplayPort 1.4
- Obsługa odtwarzania 4K Ultra HD (UHD) z portami HDMI 2,1 i DisplayPort 1.4
- Obsługa Microsoft PlayReady®

Audio

- Dźwięk HD 7.1 CH (kodek audio Realtek ALC887)
- Obsługa zabezpieczenia przed przepięciami

LAN

- 1 x PCIE Gigabit LAN 10/100/1000 Mb/s
- Realtek RTL8111H
- Obsługa Wake-On-LAN
- Obsługa zabezpieczenia przed wyładowaniami atmosferycznymi/ESD
- Obsługa Energy Efficient Ethernet 802.3az
- Obsługa PXE

Bezprzewodowa sieć LAN

- Moduł WiFi Intel® 802.11ac
- Obsługa IEEE 802.11a/b/g/n/ac
- Obsługa dwóch pasm (2,4/5 GHz)
- Obsługa wysokiej szybkości połączeń bezprzewodowych do 433 Mbps
- Obsługa Bluetooth 4.2 + Wysokiej szybkości klasa II

- Tylny panel**
- 2 x porty anteny
- Wejścia/ Wyjścia**
- 1 x port myszy/klawiatury PS/2
 - 1 x port HDMI
 - 1 x DisplayPort 1.4
 - 2 x porty USB 2.0 (Obsługa zabezpieczenia ESD)
 - 3 x port USB 3.2 Gen1 typu A (obsługuje zabezpieczenia ESD)
 - 1 x port USB 3.2 Gen1 typu C (obsługuje zabezpieczenia ESD)
 - 1 x port LAN RJ-45 z LED (LED ACT/LINK i LED SPEED)
 - Gniazda audio HD: Wejście liniowe / Głośnik przedni / Mikrofon

- Przechowywanie**
- 4 x złącza SATA3 6,0 Gb/s, obsługa RAID (RAID 0, RAID 1 i RAID 10), NCQ, AHCI i Hot Plug
 - 1 x gniazdo Ultra M.2 (M2_1), obsługa M Key typu 2280 modułu M.2 SATA3 6,0 Gb/s i modułu M.2 PCI Express do Gen3x4 (32 Gb/s)*
- * Obsługa SSD NVMe, jako dysków rozruchowych
- * Obsługa ASRock U.2 Kit

- Złącze**
- 1 x złącze główkowe LED RGB
- * Obsługa łącznie do 12V/3A, pasek LED 36W
- 1 x Adresowalne złącze główkowe LED
- * Obsługa łącznie do 5V/3A, pasek LED 15W
- 1 x złącze wentylatora CPU (4-pinowe)
- * Złącze wentylatora CPU obsługuje wentylator CPU maksymalnym prądem zasilania wentylatora 1A (12W).
- 2 x złącza wentylatora obudowy/pompy wodnej (4-pinowe) (Inteligentne sterowanie prędkością obrotową wentylatora)
- * Złącze wentylatora obudowy/pompy wodnej obsługuje wentylator układu chłodzenia maksymalnym prądem zasilania wentylatora 2A (24W).
- * CHA_FAN1/WP i CHA_FAN2/WP może automatycznie wykrywać, jeśli używany jest wentylator 3-pinowy lub 4-pinowy.
- 1 x 24 pinowe złącze zasilania ATX
 - 1 x 8 pinowe złącze zasilania 12 V
 - 1 x złącze audio na panelu przednim
 - 1 x złącza główkowe USB 2.0 (obsługuje 2 porty USB 2.0) (Obsługa zabezpieczenia ESD)
 - 1 x porty główkowe USB 3.2 Gen1 (obsługa 2 portów USB 3.2 Gen1) (obsługa zabezpieczenia ESD)

Funkcja BIOS

- Obsługa starszych wersji BIOS AMI UEFI z GUI
- Obsługa “Plug and Play”
- Zgodność zdarzeń wybudzania z ACPI 5.1
- Obsługa bezzworkowa
- Obsługa SMBIOS 2.3
- Wiele regulacji napięcia CPU, CPU VDDCR_SOC, DRAM, VPPM, +1,8VSB, VDDP

Monitor sprzętu

- Wykrywanie temperatury: CPU, wentylatory obudowy/pompy wodnej
- Obrotomierz wentylatora: CPU, wentylatory obudowy/pompy wodnej
- Cichy wentylator (Automatyczna regulacja prędkości obrotowej wentylatora obudowy przez temperaturę CPU): CPU, wentylatory obudowy/pompy wodnej
- Kontrola wielu prędkości obrotowych wentylatora: CPU, wentylatory obudowy/pompy wodnej
- Monitorowanie napięcia: Napięcie rdzenia CPU Vcore +12 V, +5 V, +3,3 V

System operacyjny

- Microsoft® Windows® 10 64-bitowy

Certyfikaty

- FCC, CE
- Gotowość do obsługi ErP/EuP (Wymagane zasilanie z gotowością obsługi ErP/EuP)

규격

플랫폼

- Mini-ITX 폼 팩터
- 솔리드 콘덴서 구조

CPU

- Ryzen™ 그래픽 프로세서 (3000 및 4000 시리즈 프로세서)를 탑재한 3세대 AMD AM4 Ryzen™/Ryzen™ 지원이상을 지원합니다 *
- * AMD Ryzen™ 5 3400G 및 Ryzen™ 3 3200G 와 호환되지 않음 .
- Digi Power design
- 8 개 전원 위상 구조

칩세트

- AMD A520

메모리

- 듀얼 채널 DDR4 메모리 기술
- DDR4 DIMM 슬롯 2 개
- AMD Ryzen 시리즈 CPU (Matisse) 는 DDR4 4600+(OC)/4533(OC)/4466(OC)/4400(OC)/4333(OC)/4333(OC)/4266(OC)/4200(OC)/4133(OC)/4000(OC)/3866(OC)/3800(OC)/3733(OC)/3600(OC)/3466(OC)/3200/2933/2667/2400/2133 및 비 ECC, 비버퍼링 메모리를 지원합니다 *
- AMD Ryzen 시리즈 APU(Renoir) 는 DDR4 4733+(OC)/4666(OC)/4600(OC)/4533(OC)/4466(OC)/4400(OC)/4333(OC)/4266(OC)/4200(OC)/4133(OC)/4000(OC)/3866(OC)/3800(OC)/3733(OC)/3600(OC)/3466(OC)/3200/2933/2667/2400/2133 및 비 ECC, 비버퍼링 메모리를 지원합니다 *
- * 추가 정보를 원하시면 ASRock 웹사이트에 있는 메모리 지원 목록을 참조하십시오 . (<http://www.asrock.com/>)
- * DDR4 UDIMM 최대 주파수 지원은 24 페이지를 참조하십시오 .
- 시스템 메모리 최대 용량 : 64GB
- Extreme Memory Profile(XMP) 메모리 모듈 지원
- DIMM 슬롯에 15μ Gold Contact 장착

확장 슬롯

- PCI Express 3.0 x16 슬롯 1 개 (PCIe1: x16 모드)*
- * x8/x8 슬롯을 확장하기 위해 PCIe 라이저 카드를 지원합니다 .
- * NVMe SSD 를 부팅 디스크로 사용 가능하도록 지원
- 수직 M.2 소켓 (키 E) 1 개 (번들로 제공되는 후면 I/O 의 WiFi-802.11ac 모듈 포함)

그래픽

- Ryzen Series APU 의 통합형 AMD Radeon™ Vega Series 그래픽 *
- * 실제 지원은 CPU 에 따라 다를 수 있음
- DirectX 12, Pixel Shader 5.0
- 기본 공유 메모리는 2GB 입니다 . 최대 공유 메모리는 16GB 까지 지원됩니다 .
- * 최대 공유 메모리로 16GB 를 사용하려면 32GB 의 시스템 메모리가 설치되어 있어야 합니다 .
- 이중 그래픽 출력 : 독립적 디스플레이 컨트롤러로 HDMI 및 DisplayPort 1.4 포트 지원
- HDMI 2.1 지원 (최대 해상도 4K x 2K (4096x2160) @ 60Hz)
- DisplayPort 1.4 입력 지원 (최대 해상도 5K(5120x2880) @ 120Hz)
- Auto Lip Sync, Deep Color (12bpc), xvYCC 및 HBR (High Bit Rate Audio)(HDMI 2.1 포트 포함) 지원 (HDMI 호환 모니터 필요)
- HDMI 2.1 에서 HDR(높은 동적 범위) 를 지원합니다 .
- HDCP 2.3(HDMI 2.1 및 DisplayPort 1.4 포트 포함) 지원
- HDMI 2.1 및 DisplayPort 1.4 포트를 이용한 4K Ultra HD(UHD) 재생 지원
- Microsoft PlayReady® 지원

오디오

- 7.1 CH HD 오디오 (Realtek ALC887 오디오 코덱)
- 서비 보호 지원

LAN

- PCIE 1 개 , Gigabit LAN 10/100/1000 Mb/s
- Realtek RTL8111H
- Wake-On-LAN 지원
- 번개 /ESD 보호 지원
- 절전형 이더넷 802.3az 지원
- PXE 지원

무선 LAN

- Intel® 802.11ac WiFi 모듈
- IEEE 802.11a/b/g/n/ac 지원
- 듀얼 밴드 (2.4/5 GHz) 지원
- 최대 433Mbps 의 고속 무선 연결 지원
- Bluetooth 4.2+ 고속 클래스 II 지원

후면 패널 I/O

- 안테나 포트 2 개
- PS/2 마우스 / 키보드 포트 1 개
- HDMI 포트 1 개
- DisplayPort 1.4 1 개
- USB 2.0 포트 2 개 (ESD 보호 지원)
- USB 3.2 Gen1 타입 A 포트 3 개 (ESD 보호 지원)
- USB 3.2 Gen1 타입 C 포트 1 개 (ESD 보호 지원)
- LED 장착 RJ-45 LAN 포트 1 개 (ACT/LINK LED 및 SPEED LED)
- HD 오디오 잭 : 라인 입력 / 전면 스피커 / 마이크

저장 장치

- SATA3 4 Gb/s 커넥터 6 개가 RAID(RAID 0, RAID 1 및 RAID 10), NCQ, AHCI 및 핫 플러그를 지원합니다.
- 울트라 M.2 하이퍼 (M2_1) 1 개, M 키 타입 2280 M.2 SATA3 6.0 Gb/s 모듈 및 Gen3x4 의 경우 4 개 (32Gb/s) 까지 지원 *
- * NVMe SSD 를 부팅 디스크로 사용 가능하도록 지원
- * ASRock U.2 키트 지원

커넥터

- RGB LED 헤더 1 개
- * 전체 최대 12V/3A, 36W LED 스트립 지원
- 주소 지정 가능한 LED 헤더 1 개
- * 전체 최대 5V/3A, 15W LED 스트립 지원
- CPU 팬 커넥터 (4 핀) 1 개
- * CPU 팬 커넥터는 팬 전력이 최대 1A(12W) 인 CPU 팬을 지원합니다.
- 새시 / 워터 펌프 팬 커넥터 (4 핀) 2 개 (스마트 팬 속도 제어)
- * 새시 / 워터 펌프 팬은 팬 전력이 최대 2A(24W) 인 수냉식 쿨러 팬을 지원합니다.
- * 3 핀 또는 4 핀 팬이 사용 중인 경우, CHA_FAN1/WP 과 CHA_FAN2/WP 가 자동으로 감지할 수 있습니다.
- 24 핀 ATX 전원 커넥터 1 개
- 8 핀 12V 전원 커넥터 1 개
- 전면 패널 오디오 커넥터 1 개
- USB 2.0 헤더 1 개 (USB 2.0 포트 2 개 지원) (ESD 보호 지원)
- USB 3.2 Gen1 헤더 1 개 (USB 3.2 Gen1 포트 2 개 지원) (ESD 보호 지원)

BIOS 기능

- GUI 지원을 제공하는 AMI UEFI 적합형 BIOS
- “플러그 앤드 플레이” 지원
- ACPI 5.1 준수 웨이크 업 이벤트
- 점퍼 프리 지원
- SMBIOS 2.3 지원
- CPU, CPU VDDCR_SOC, DRAM, VPPM, +1.8VSB, VDDP 전압 다중 조정

하드웨어 모니터

- 온도 감지 : CPU, 새시 / 워터 펌프 팬
- 팬 타코미터 : CPU, 새시 / 워터 펌프 팬
- 저소음 팬 (CPU 온도에 의한 새시 팬 속도 자동 조절): CPU, 새시 / 워터 펌프 팬
- 팬 다중 속도 제어 : CPU, 새시 / 워터 펌프 팬
- 전압 모니터링 : +12V, +5V, +3.3V, CPU Vcore

OS

- Microsoft® Windows® 10 64- 비트

인증

- FCC, CE
- ErP/EuP 사용 가능 (ErP/EuP 사용 가능 전원공급장치 필요)

仕様

- プラットフォーム**
- Mini-ITX フォームファクター
 - 固体コンデンサ設計

- CPU**
- Ryzen™ グラフィックスプロセッサ (3000 および 4000 シリーズプロセッサ) と共に第 3 世代以降の AMD AM4 Ryzen™/Ryzen™ に対応します *
- * AMD Ryzen™ 5 3400G および Ryzen™ 3 3200G と互換性はありません
- デジタル電源設計
 - 8 電源フェーズ設計

- チップセット**
- AMD A520

- メモリ**
- デュアルチャンネル DDR4 メモリ機能
 - 2 x DDR4 DIMM スロット
 - AMD Ryzen シリーズ CPU (Matisse) は、DDR4 4600+(OC)/4533(OC)/4466(OC)/4400(OC)/4333(OC)/4333(OC)/4266(OC)/4200(OC)/4133(OC)/4000(OC)/3866(OC)/3800(OC)/3733(OC)/3600(OC)/3466(OC)/3200/2933/2667/2400/2133 ECC および非 ECC、アンバッファードメモリに対応します *
 - AMD Ryzen シリーズ APU (Renoir) は、DDR4 4733+(OC)/4666(OC)/4600(OC)/4533(OC)/4466(OC)/4400(OC)/4333(OC)/4266(OC)/4200(OC)/4133(OC)/4000(OC)/3866(OC)/3800(OC)/3733(OC)/3600(OC)/3466(OC)/3200/2933/2667/2400/2133 ECC および非 ECC、アンバッファードメモリに対応します *
- * 詳細については、ASRock ウェブサイトのメモリーサポート一覧を参照してください。(http://www.asrock.com/)
- * DDR4 UDIMM 最大周波数サポートについては 24 ページを参照してください。
- システムメモリの最大容量: 64GB
 - Extreme Memory Profile (XMP) メモリモジュールに対応します
 - DIMM スロットに 15μ ゴールドコンタクトを採用

- 拡張スロット**
- 1 x PCI Express 3.0 x16 スロット (PCIe1: x16 モード)*
- * x8/x8 スロットに拡張するために PCIe ライザーカードに対応
- * 起動ディスクとして NVMe SSD に対応
- 1 x 垂直 M.2 ソケット (Key E)、WiFi-802.11ac モジュールがバンドルされています (リア I/O)

グラフィックス

- AMD Radeon™ Vega シリーズグラフィックスを Ryzen シリーズ APU に統合 *
- * 実際のサポートは CPU によって異なることがあります
- DirectX 12、Pixel Shader 5.0
- 共有メモリはデフォルトでは 2GB に設定されています。最大共有メモリは 16GB まで対応します。
- * 最大共有メモリが 16GB の場合は、32GB のシステムメモリがインストールされていなければなりません。
- デュアルグラフィックス出力: 独立したディスプレイコントローラで HDMI ポートと DisplayPort 1.4 ポートに対応
- HDMI 2.1 テクノロジーに対応、最大解像度 4K x 2K (4096x2160) @ 60Hz
- 最大 5K (5120x2880、120Hz 時)の解像度で DisplayPort 1.4 入力に対応します
- HDMI 2.1 ポートでオートリップシンク、ディープカラー (12bpc)、xvYCC、および、HBR (高ビットレートオーディオ)に対応 (HDMI 対応モニターが必要です)
- HDMI 2.1 の高ダイナミックレンジ (HDR) に対応
- HDMI 2.1 ポートと DisplayPort 1.4 ポートで HDCP 2.3 に対応
- HDMI 2.1 ポートと DisplayPort 1.4 ポートで 4K Ultra HD (UHD) 再生に対応
- Microsoft PlayReady® に対応

オーディオ

- 7.1 CH HD オーディオ (Realtek ALC887 Audio Codec)
- サージ保護に対応

LAN

- PCIE x1 ギガビット LAN 10/100/1000 Mb/s
- Realtek RTL8111H
- Wake-On-LAN (ウェイク オン ラン) に対応
- 雷 / 静電気放電 (ESD) 保護に対応
- エネルギー効率のよいイーサネット 802.3az をサポート
- PXE をサポート

ワイヤレス**LAN**

- Intel® 802.11ac WiFi モジュール
- IEEE 802.11a/b/g/n/ac をサポート
- デュアルバンド (2.4/5 GHz) をサポート
- 最高 433 Mbps の高速ワイヤレス接続をサポート
- ブルートゥース 4.2 + ハイスピードクラス II をサポート

リアパネル I/O

- 2 x アンテナポート
- 1 x PS/2 マウス / キーボードポート
- 1 x HDMI ポート
- 1 x DisplayPort 1.4
- 2 x USB 2.0 ポート(静電気放電 (ESD) 保護に対応)
- 3 x USB 3.2 Gen1 Type-A ポート(静電気放電 (ESD) 保護に対応)
- 1 x USB 3.2 Gen1 Type-C ポート(静電気放電 (ESD) 保護に対応)
- LED 付き 1 x RJ-45 LAN ポート(ACT/LINK LED と SPEED LED)
- HD オーディオジャック: ラインイン / フロントスピーカー / マイク

ストレージ

- 4 x SATA3 6.0 Gb/s コネクタ、RAID (RAID 0、RAID 1、RAID 10)、NCQ、AHCI およびホットプラグ機能に対応
- 1 x Ultra M.2 Socket (M2_1) は、M Key タイプ 2280 M.2 SATA3 6.0 Gb/s モジュール、および、最大 Gen3x4 (32 Gb/s) までの M.2 PCI Express モジュールに対応 *
- * 起動ディスクとして NVMe SSD に対応
- * ASRock U.2 キットに対応

コネクタ

- 1 x RGB LED ヘッダー
- * 合計 12V/3A、36W までの LED ストリップに対応
- 1 x アドレスラブル LED ヘッダー
- * 合計 5V/3A、15W までの LED ストリップに対応
- 1 x CPU ファンコネクタ (4 ピン)
- * CPU ファンコネクタは最大 1A (12W) の電力の CPU ファンに対応します。
- 2 x シャーシ / ウォーターポンプファンコネクタ (4 ピン) (スマートファン速度制御)
- * シャーシ / ウォーターポンプファンは最大 2A (24W) の出力のウォータークーラーに対応します。
- * CPU_FAN1/WP および CHA_FAN2/WP は 3 ピンまたは 4 ピンファンが使用されているかどうかを自動検出できます。
- 1 x 24 ピン ATX 電源コネクタ
- 1 x 8 ピン 12V 電源コネクタ
- 1 x 前面パネルオーディオコネクタ
- 1 x USB 2.0 ヘッダー (2 つの USB 2.0 ポートに対応) (静電気放電 (ESD) 保護に対応)

- 1 x USB 3.2 Gen1 ヘッダー (2 つの USB 3.2 Gen1 ポートに対応) (静電気放電 (ESD) 保護に対応)

BIOS 機能

- AMI UEFI Legal BIOS、GUI サポート付き
- 「ブラダアンドブレイ」をサポート
- ACPI 5.1 準拠のウェイクアップイベント
- ジャンパーフリーをサポート
- SMBIOS 2.3 サポート
- CPU、CPU、VDDCR_SOC、DRAM、VPPM、+1.8VSB、VDDP 電圧マルチ調整

**ハードウェア
アモニター**

- 温度センシング：CPU、シャーシ / ウォーターポンプファン
- ファンタコメータ：CPU、シャーシ / ウォーターポンプファン
- 静音ファン（CPU 温度に従ってシャーシファン速度を自動調整）：CPU、シャーシ / ウォーターポンプファン
- ファンマルチ速度制御：CPU、シャーシ / ウォーターポンプファン
- 電圧監視：+12V、+5V、+3.3V、CPU Vcore

OS

- Microsoft® Windows® 10 64-bit

認証

- FCC、CE
- ErP/EuP Ready (ErP/EuP 対応電源供給装置が必要です)

规格

- 平台**
- Mini-ITX 规格尺寸
 - 稳固的电容器设计

- CPU**
- 支持第 3 代 AMD AM4 Ryzen™ / 将来的 AMD Ryzen™ 处理器（3000 和 4000 系列处理器）*
 - * 不兼容 AMD Ryzen™ 5 3400G 和 Ryzen™ 3 3200G。
 - Digi Power design
 - 8 电源相设计

- 芯片集**
- AMD A520

- 内存**
- 双通道 DDR4 内存技术
 - 2 x DDR4 DIMM 槽
 - AMD Ryzen 系列 CPU (Matisse) 支持 DDDR4 4600+(OC)/4533(OC)/4466(OC)/4400(OC)/4333(OC)/4333(OC)/4266(OC)/4200(OC)/4133(OC)/4000(OC)/3866(OC)/3800(OC)/3733(OC)/3600(OC)/3466(OC)/3200/2933/2667/2400/2133 ECC 及非 ECC，非缓冲内存 *
 - AMD Ryzen 系列 APU (Renoir) 支持 DDR4 4733+(OC)/4666(OC)/4600(OC)/4533(OC)/4466(OC)/4400(OC)/4333(OC)/4266(OC)/4200(OC)/4133(OC)/4000(OC)/3866(OC)/3800(OC)/3733(OC)/3600(OC)/3466(OC)/3200/2933/2667/2400/2133 ECC 及非 ECC，非缓冲内存 *
 - * 请参阅华擎网站上的 Memory Support List（内存支持列表）了解详情。（<http://www.asrock.com/>）
 - * 请参考第 24 页了解 DDR4 UDIMM 最大支持频率。
 - 支持系统内存最大容量：64GB
 - 支持 Extreme Memory Profile (XMP) 内存模块
 - DIMM 插槽中 15μ 金触点

- 扩充槽**
- 1 x PCI Express 3.0 x16 插槽（PCIe1：x16 模式）*
 - * 支持 PCIe 扩展卡，可扩展 x8/x8 插槽
 - * 支持 NVMe SSD 用作启动盘
 - 1 x 垂直 M.2 Socket (Key E)，捆绑有 WiFi-802.11ac 模块（在后 I/O 上）

图形

- Ryzen 系列 APU 中的集成 AMD Radeon™ Vega 系列图形 *
- * 实际支持可能视 CPU 而变化
- DirectX 12、Pixel Shader 5.0
- 默认共享内存 2GB。最大共享内存达 16GB。
- * 最大共享内存 16GB 需要安装 32GB 系统内存。
- 双图形输出：通过独立显示控制器支持 HDMI 和 DisplayPort 1.4 端口
- 支持 HDMI 2.1，60Hz 时最大分辨率达 4K x 2K (4096x2160)
- 支持 DisplayPort 1.4 输入，120Hz 时最大分辨率达 5K (5120x2880)
- 通过 HDMI 2.1 端口（需要兼容的 HDMI 显示器）支持 Auto Lip Sync、Deep Color (12bpc)、xvYCC 和 HBR（高位速率音频）
- 通过 HDMI 2.1 支持 HDR（高动态范围）
- 通过 HDMI 2.1 和 DisplayPort 1.4 端口支持 HDCP 2.3
- 通过 HDMI 2.1 和 DisplayPort 1.4 端口支持支持 4K 超高清 (UHD) 播放
- 支持 Microsoft PlayReady®

音频

- 7.1 CH 高清音频（Realtek ALC887 音频编解码器）
- 支持电涌保护

LAN

- PCIE x1 Gigabit LAN 10/100/1000 Mb/s
- Realtek RTL8111H
- 支持 Wake-On-LAN（网上唤醒）
- 支持雷电 /ESD 保护
- 支持高效以太网 802.3az
- 支持 PXE

无线 LAN

- Intel® 802.11ac WiFi 模块
- 支持 IEEE 802.11a/b/g/n/ac
- 支持双频段 (2.4/5 GHz)
- 支持最高 433Mbps 的高速无线连接
- 支持 Bluetooth 4.2+ 高速 Class II

后面板 I/O

- 2 x 天线端口
- 1 x PS/2 鼠标 / 键盘端口
- 1 x HDMI 端口
- 1 x DisplayPort 1.4
- 2 x USB 2.0 端口 (支持 ESD 保护)
- 3 x USB 3.2 Gen1 A 类型端口 (支持 ESD 保护)
- 1 x USB 3.2 Gen1 C 类型端口 (支持 ESD 保护)
- 1 x RJ-45 LAN 端口, 带 LED (ACT/LINK LED 和 SPEED LED)
- 高清音频插孔: 线路输入 / 前扬声器 / 麦克风

存储

- 4 x SATA3 6.0 Gb/s 接口, 支持 RAID (RAID 0、RAID 1 和 RAID 10)、NCQ、AHCI 和热插拔
- 1 x Ultra M.2 接口 (M2_1), 支持 M Key 类型 2280 M.2 SATA3 6.0 Gb/s 模块和 M.2 PCI Express 模块 Gen3 x4 (32 Gb/s)*
- * 支持 NVMe SSD 用作启动盘
- * 支持华擎 U.2 套件

接口

- 1 x RGB LED 接头
- * 总共支持最高 12V/3A, 36W LED 灯条
- 1 x 可寻址 LED 接脚
- * 总共支持最高 5V/3A, 15W LED 灯条
- 1 x CPU 风扇接口 (4 针)
- * CPU 风扇接口支持最高 1A (12W) 功率的 CPU 风扇。
- 2 x 机箱 / 水泵风扇接口 (4 针) (智能风扇速度控制)
- * 机箱 / 水泵风扇支持最高 2A (24W) 功率的水冷风扇。
- * CHA_FAN1/WP 和 CHA_FAN2/WP 可以自动检测 3 针脚或 4 针脚风扇是否在使用。
- 1 x 24 针 ATX 电源接口
- 1 x 8 针 12V 电源接口
- 1 x 前面板音频接口
- 1 x USB 2.0 接脚 (支持 2 个 USB 2.0 端口, 支持 ESD 保护)
- 1 x USB 3.2 Gen1 接脚 (支持 2 个 USB 3.2 Gen1 端口, 支持 ESD 保护)

BIOS 功能特点

- AMI UEFI Legal BIOS，支持 GUI
- 支持“即插即用”
- ACPI 5.1 兼容唤醒事件
- 支持免跳线 (jumperfree)
- 支持 SMBIOS 2.3
- CPU、CPU VDDCR_SOC、DRAM、VPPM、+1.8VSB、VDDP 电压多次调整 (Voltage Multi-adjustment)

硬件监控

- 温度感测：CPU、机箱 / 水泵风扇
- 风扇转速计：CPU、机箱 / 水泵风扇
- 静音风扇（根据 CPU 温度自动调整机箱风扇速度）：CPU、机箱 / 水泵风扇
- 风扇多种速度控制：CPU、机箱 / 水泵风扇
- 电压监控：+12V、+5V、+3.3V、CPU Vcore

操作系统

- Microsoft® Windows® 10 64-bit

认证

- FCC、CE
- ErP/EuP 支持（需要支持 ErP/EuP 的电源）

規格

- 平台
- Mini-ITX 尺寸
 - 固態電容設計

- CPU
- 支援第 3 代 AMD AM4 Ryzen™ / 未來的 AMD Ryzen™ 處理器 (3000 與 4000 系列處理器) *
 - * 不相容於 AMD Ryzen™ 5 3400G 與 Ryzen™ 3 3200G。
 - Digi Power design
 - 8 電源相位設計

- 晶片組
- AMD A520

- 記憶體
- 雙通道 DDR4 記憶體技術
 - 2 x DDR4 DIMM 插槽
 - AMD Ryzen 系列 CPU (Matisse) 支援 DDR4 4600+(OC)/4533(OC)/4466(OC)/4400(OC)/4333(OC)/4333(OC)/4266(OC)/4200(OC)/4133(OC)/4000(OC)/3866(OC)/3800(OC)/3733(OC)/3600(OC)/3466(OC)/3200/2933/2667/2400/2133 ECC、無緩衝記憶體 *
 - AMD Ryzen 系列 APU (Renoir) 支援 DDR4 4733+(OC)/4666(OC)/4600(OC)/4533(OC)/4466(OC)/4400(OC)/4333(OC)/4266(OC)/4200(OC)/4133(OC)/4000(OC)/3866(OC)/3800(OC)/3733(OC)/3600(OC)/3466(OC)/3200/2933/2667/2400/2133 ECC & 非 ECC、無緩衝記憶體 *
 - * 如需更多資訊，請參閱華擎網站上的記憶體支援表。
(<http://www.asrock.com/>)
 - * 關於 DDR4 UDIMM 最高頻率支援，請參閱第 24 頁。
 - 最大系統記憶體容量：64GB
 - 支援 Extreme Memory Profile (XMP) 記憶體模組
 - 15μ 特厚鍍金插槽

- 擴充插槽
- 1 x PCI Express 3.0 x16 插槽 (PCIe1 : x16 模式) *
 - * 支援 PCIe 豎卡，以擴充 x8/x8 插槽
 - * 支援 NVMe SSD 作為開機磁碟
 - 1 x 垂直 M.2 插座 (Key E)，搭售 WiFi-802.11ac 模組 (在後置 I/O 上)

顯示卡

- 整合式 AMD Radeon™ Vega Series Graphics 內建於 Ryzen 系列 APU*
- * 實際支援可能隨 CPU 改變
- DirectX 12、Pixel Shader 5.0
- 預設共用記憶體 2GB。最大共用記憶體達 16GB。
- * 最大共用記憶體 16GB 需要安裝 32GB 系統記憶體。
- 雙圖形輸出：透過獨立顯示控制器支援 HDMI 及 DisplayPort 1.4 連接埠
- 最高支援 4K x 2K (4096x2160) @ 60Hz 解析度的 HDMI 2.1
- 支援最高達 5K (5120x2880)@120Hz 解析度的 DisplayPort 1.4 輸入
- 支援使用 HDMI 2.1 連接埠（需相容於 HDMI 顯示器）的 Auto Lip Sync、Deep Color (12bpc)、xvYCC 及 HBR（高位元率音訊）
- 使用 HDMI 2.1 支援 HDR（高動態範圍）
- 支援含 HDMI 2.1 及 DisplayPort 1.4 連接埠的 HDCP 2.3
- 支援使用 HDMI 2.1 與 DisplayPort 1.4 連接埠進行 4K Ultra HD (UHD) 播放
- 支援 Microsoft PlayReady®

音訊

- 7.1 CH HD 音訊（Realtek ALC887 音訊轉碼器）
- 支援突波保護

LAN

- PCIE x1 Gigabit LAN 10/100/1000 Mb/s
- Realtek RTL8111H
- 支援網路喚醒
- 支援雷擊／靜電保護
- 支援 802.3az EEE 節能乙太網路
- 支援 PXE

無線 LAN

- Intel® 802.11ac WiFi 模組
- 支援 IEEE 802.11a/b/g/n/ac
- 支援雙頻 (2.4/5 GHz)
- 支援高達 433Mbps 的高速無線連線
- 支援 Bluetooth 4.2 + 高速級別 II

後面板 I/O

- 2 x 天線連接埠
- 1 x PS/2 滑鼠／鍵盤連接埠
- 1 x HDMI 連接埠
- 1 x DisplayPort 1.4
- 2 x USB 2.0 連接埠（支援靜電保護）
- 3 x USB 3.2 Gen1 A 類型連接埠（支援靜電保護）
- 1 x USB 3.2 Gen1 C 類型連接埠（支援靜電保護）
- 1 x RJ-45 LAN 連接埠，含 LED（ACT/LINK LED 及 SPEED LED）
- HD 音訊插孔：線路輸入／前置喇叭／麥克風

儲存裝置

- 提供 4 x SATA3 6.0 Gb/s 接頭，支援 RAID（RAID 0、RAID 1、與 RAID 10）、NCQ、AHCI 及熱插拔
 - 1 x Ultra M.2 插座 (M2_1)，支援 M Key 型 2280 M.2 SATA3 6.0 Gb/s 模組與 M.2 PCI Express 模組（最高可達 Gen3x4 (32 Gb/s)*)
- * 支援 NVMe SSD 作為開機磁碟
* 支持華擎 U.2 套件

接頭

- 1 x RGB LED 排針
- * 總計最高支援 12V/3A，36W LED 條燈
- 1 x 可定址 LED 排針
- * 總計最高支援 5V/3A，15W LED 條燈
- 1 x CPU 風扇接頭 (4-pin)
- * CPU 風扇接頭支援最高 1A (12W) 風扇功率的 CPU 風扇。
- 2 x 機殼／水冷幫浦風扇接頭 (4-pin)（智慧型風扇速度控制）
- * 機殼／水冷幫浦風扇接頭支援最高 2A (24W) 風扇功率的水冷風扇。
- * 如果 3-pin 或 4-pin 風扇使用中，可自動偵測 CHA_FAN1/WP 和 CHA_FAN2/WP。
- 1 x 24 pin ATX 電源接頭
 - 1 x 8 pin 12V 電源接頭
 - 1 x 前面板音訊接頭
 - 1 x USB 2.0 排針（支援 2 個 USB 2.0 連接埠）（支援靜電保護）
 - 1 x USB 3.2 Gen1 排針（支援 2 個 USB 3.2 Gen1 連接埠）（支援靜電保護）

BIOS 功能

- AMI UEFI Legal BIOS 含 GUI 支援
- 支援「隨插即用」
- ACPI 5.1 符合喚醒自動開機
- 支援免跳線模式
- 支援 SMBIOS 2.3
- CPU、CPU VDDCR_SOC、DRAM、VPPM、+1.8VSB、VDDP 電壓多重調整

硬體顯示器

- 溫度感應：CPU、機殼／水冷幫浦風扇
- 風扇轉速計：CPU、機殼／水冷幫浦風扇
- 靜音風扇（依 CPU 溫度自動調整機殼風扇速度）：CPU、機殼／水冷幫浦風扇
- 風扇多重速度控制：CPU、機殼／水冷幫浦風扇
- 電壓監控：+12V、+5V、+3.3V、CPU Vcore

作業系統

- Microsoft® Windows® 10 64-bit

認證

- FCC、CE
- ErP/EuP ready（須具備 ErP/EuP ready 電源供應器）

Spesifikasi

- Platform**
- Bentuk dan Ukuran Mini-ITX
 - Desain Kapasitor Solid

- CPU**
- Mendukung AMD AM4 Ryzen™ Gen 3 / AMD Ryzen™ Prosesor masa depan (Prosesor Seri 3000 dan 4000)*
 - * Tidak kompatibel dengan AMD Ryzen™ 5 3400G dan Ryzen™ 3 3200G.
 - Desain Digi Power
 - Desain 8 Fase Daya

- Chipset**
- AMD B550

- Memori**
- Teknologi Memori DDR4 Dua Saluran
 - 2 x Slot DIMM DDR4
 - CPU seri AMD Ryzen (Matisse) yang mendukung memori ECC & non-ECC, tanpa buffering DDR4 4600+(OC)/4533(OC)/4466(OC)/4400(OC)/4333(OC)/4333(OC)/4266(OC)/4200(OC)/4133(OC)/4000(OC)/3866(OC)/3800(OC)/3733(OC)/3600(OC)/3466(OC)/3200/2933/2667/2400/2133*
 - APU seri AMD Ryzen (Renoir) yang mendukung memori ECC & non-ECC, tanpa buffering DDR4 4733+(OC)/4666(OC)/4600(OC)/4533(OC)/4466(OC)/4400(OC)/4333(OC)/4266(OC)/4200(OC)/4133(OC)/4000(OC)/3866(OC)/3800(OC)/3733(OC)/3600(OC)/3466(OC)/3200/2933/2667/2400/2133*
 - * Lihat Daftar Dukungan Memori di situs web ASRock untuk informasi selengkapnya. (<http://www.asrock.com/>)
 - * Lihat halaman 24 untuk dukungan frekuensi maksimum DDR4 UDIMM.
 - Kapasitas maksimum memori sistem: 64GB
 - Mendukung modul memori Extreme Memory Profile (XMP)
 - 15µ Bidang Kontak Berwarna Emas di Slot DIMM

- Slot Ekspansi**
- 1 x Slot PCI Express 3.0 x16 (PCIe1: x16 mode)*
 - * Mendukung kartu riser PCIe untuk memperpanjang slot x8/x8
 - * Mendukung SSD NVMe sebagai disk boot
 - 1 x Soket M.2 Vertikal (tombol E) dengan paket modul WiFi-802.11ac (di bagian belakang I/O)

Grafis

- Grafis AMD Radeon™ Terpadu Seri Vega dalam APU Seri Ryzen*

* Dukungan sebenarnya mungkin beragam berdasarkan CPU

- DirectX 12, Pixel Shader 5.0
- Default memori bersama 2GB. Memori bersama maksimum mendukung hingga 16GB.

* Memori bersama maksimum 16GB mengharuskan memori sistem 32GB terpasang.

- Output grafis ganda: Mendukung port HDMI dan DisplayPort 1.4 melalui pengontrol layar mandiri
- Mendukung HDMI 2.1 dengan resolusi maksimum hingga 4K x 2K (4096x2160) @ 60Hz
- Mendukung Input DisplayPort 1.4 dengan resolusi maksimum hingga 5K (5120x2880) @ 120Hz
- Mendukung Auto Lip Sync, Kedalaman Warna (12bpc), xvYCC, dan HBR (Audio High Bit Rate) dengan Port HDMI 2.1 (memerlukan monitor yang kompatibel dengan HDMI)
- Mendukung HDR (High Dynamic Range) dengan HDMI 2.1
- Mendukung HDCP 2.3 dengan Port HDMI 2.1 dan DisplayPort 1.4
- Mendukung pemutaran Ultra HD 4K (UHD) dengan Port HDMI 2.1 dan DisplayPort 1.4
- Mendukung Microsoft PlayReady®

Audio

- Audio HD 7.1 CH (Realtek ALC887 Audio Codec)
- Mendukung Perlindungan dari Lonjakan Arus

LAN

- 1 x PCIE Gigabit LAN 10/100/1000 Mb/s
- Realtek RTL8111H
- Mendukung Wake-On-LAN
- Mendukung Perlindungan dari Petir/ESD
- Mendukung Ethernet 802.3az Hemat Energi
- Mendukung PXE

LAN**Nirkabel**

- Intel® 802.11ac WiFi Modul
- Mendukung IEEE 802.11a/b/g/n/ac
- Mendukung Dual-Band (2,4/5 GHz)
- Mendukung Sambungan nirkabel berkecepatan tinggi hingga 433Mbps
- Mendukung Bluetooth 4.2 + Kecepatan tinggi kelas II

I/O Panel Belakang

- 2 x Port Antena
- 1 x Port Mouse/Keyboard PS/2
- 1 x Port HDMI
- 1 x DisplayPort 1.4
- 2 x Port USB 2.0 (Mendukung Perlindungan dari ESD)
- 3 x USB 3.2 Gen1 Port Tipe A (Mendukung Perlindungan dari ESD)
- 1 x USB 3.2 Gen1 Port Tipe C (Mendukung Perlindungan dari ESD)
- 1 x Port LAN RJ-45 dengan LED (LED ACT/LINK dan LED SPEED)
- Soket Audio HD: Saluran Masuk/Speaker Depan/Mikrofon

Penyimpanan

- 4 x Konektor SATA3 6,0 Gb/s, mendukung RAID (RAID 0, RAID 1, dan RAID 10), NCQ, AHCI dan Hot Plug
- 1 x Soket Ultra M.2 (M2_1), mendukung modul M Key tipe 2280 M.2 SATA3 6,0 Gb/s dan modul M.2 PCI Express hingga Gen3x4 (32 Gb/s) *

* Mendukung SSD NVMe sebagai disk boot

* Mendukung Kit U.2 ASRock

Konektor

- 1 x Header LED RGB
- * Mendukung total Strip LED hingga 12V/3A, 36W
- 1 x Addressable LED Header
- * Mendukung total Strip LED hingga 5V/3A, 15W
- 1 x Konektor Kipas CPU (4-pin)
- * Konektor Kipas CPU mendukung kipas CPU dengan daya kipas maksimum 1A (12W).
- 2 x Konektor Sasis/Kipas Pompa Air (4-pin) (Kontrol Kecepatan Kipas Pintar)
- * Chassis/Kipas Pompa Air mendukung kipas berpendingin air dengan daya kipas maksimum 2A (24W).
- * CHA_FAN1/WP dan CHA_FAN2/WP dapat mendeteksi otomatis jika kipas 3-pin atau 4-pin sedang digunakan.
- 1 x Konektor Daya ATX 24 pin
- 1 x Konektor Daya 8 pin 12V
- 1 x Konektor Audio Panel Depan
- 1 x Header USB 2.0 (Mendukung 2 port USB 2.0) (Mendukung Perlindungan dari ESD)

- 1 x Header USB 3.2 Gen1 (Mendukung 2 port USB 3.2 Gen1) (Mendukung Perlindungan dari ESD)

Fitur BIOS

- AMI UEFI Legal BIOS dengan dukungan GUI
- Mendukung “Plug and Play”
- ACPI 5.1 kompatibel dengan aktivitas pengaktifan
- Mendukung jumperfree
- Dukungan SMBIOS 2.3
- CPU, CPU VDDCR_SOC, DRAM, VPPM, +1,8VSB, VDDP, Penyesuaian Multi Voltase

**Monitor
Perangkat
Keras**

- Deteksi Suhu: Kipas CPU, Sasis, Pompa Air
- Takometer Kipas: Kipas CPU, Sasis, Pompa Air
- Kipas Hening (Penyesuaian otomatis kecepatan kipas sasis berdasarkan suhu CPU): Kipas CPU, Sasis, Pompa Air
- Kontrol Multikecepatan Kipas: Kipas CPU, Sasis, Pompa Air
- Pemantauan tegangan: +12V, +5V, +3,3V, CPU Vcore

OS

- Microsoft® Windows® 10 64-bit

Sertifikasi

- FCC, CE
- Mendukung ErP/EuP (memerlukan catu daya untuk ErP/EuP)

Contact Information

If you need to contact ASRock or want to know more about ASRock, you're welcome to visit ASRock's website at <http://www.asrock.com>; or you may contact your dealer for further information. For technical questions, please submit a support request form at <http://www.asrock.com/support/tsd.asp>

ASRock Incorporation

2F., No.37, Sec. 2, Jhongyang S. Rd., Beitou District,

Taipei City 112, Taiwan (R.O.C.)

ASRock EUROPE B.V.

Bijsterhuizen 11-11

6546 AR Nijmegen

The Netherlands

Phone: +31-24-345-44-33

Fax: +31-24-345-44-38

ASRock America, Inc.

13848 Magnolia Ave, Chino, CA91710

U.S.A.

Phone: +1-909-590-8308

Fax: +1-909-590-1026

DECLARATION OF CONFORMITY

Per FCC Part 2 Section 2.1077(a)



Responsible Party Name: ASRock Incorporation

Address: 13848 Magnolia Ave, Chino, CA91710

Phone/Fax No: +1-909-590-8308/+1-909-590-1026

hereby declares that the product

Product Name : Motherboard

Model Number : A520M-ITX/ac

Conforms to the following specifications:

FCC Part 15, Subpart B, Unintentional Radiators

Supplementary Information:

This device complies with part 15 of the FCC Rules. Operation is subject to the following two conditions: (1) This device may not cause harmful interference, and (2) this device must accept any interference received, including interference that may cause undesired operation.

Representative Person's Name: James

Signature:

A handwritten signature in black ink, appearing to be 'James', written over a dotted line.

Date : May 12, 2017

EU Declaration of Conformity

ASRock®

For the following equipment:

Motherboard

(Product Name)

A520M-ITX/ac/ ASRock

(Model Designation / Trade Name)

ASRock Incorporation

(Manufacturer Name)

2F, No.37, Sec. 2, Jhongyang S. Rd., Beitou District, Taipei City 112, Taiwan (R.O.C.)

(Manufacturer Address)

EMC — Directive 2014/30/EU (from April 20th, 2016)

EN 55022:2010/AC:2011 Class B

EN 55024:2010/A1:2015

EN 55032:2012+AC:2013 Class B

EN 61000-3-3:2013

EN 61000-3-2:2014

RED—Directive 2014/53/EU

EN 300 328 V2.1.1

EN 301 489-17 V3.1.1

EN 301 893 V2.1.1

EN 301 489-3 V2.1.1

EN 300 220 V3.1.1

LVD — Directive 2014/35/EU (from April 20th, 2016)

EN 60950-1 : 2011+ A2: 2013

EN 60950-1 : 2006/A12: 2011

RoHS — Directive 2011/65/EU

CE marking



(EU conformity marking)

ASRock EUROPE B.V.

(Company Name)

Bijsterhuizen 1111 6546 AR Nijmegen The Netherlands

(Company Address)

Person responsible for making this declaration:

(Name, Surname)

A.V.P

(Position / Title)

May 27, 2020

(Date)

P/N: 15G062240000AK V1.0