

LCPOWER™

www.lc-power.com

Model	Gaming 810B - Dark_Crawler_X / Gaming 810W - Bright_Crawler_X
M/B Type	Support E-ATX, ATX, Micro-ATX, Mini-ITX
Internal Bays	up to 3x 3,5" HDD & up to 5x 2,5" SSD
Front I/O Panel	1x USB-C (3.2 Gen. 2x2), 2x USB-A (3.2 Gen. 1x1), HD Audio, Power SW, Reset SW, LED SW
Front Cooling Fan	3x 120 mm/140 mm fan or 1x 240/280/360mm water cooling radiator
Rear Cooling Fan	1x 120 mm fan or 1x 120 mm water cooling radiator
Top Cooling Fan	3x 120 mm or 2x 140 mm fan or 1x 240/280/360 mm water cooling radiator
PCI Slot	7 (horizontal/screwable) + 2 (vertical/screwable)
Graphic Card Length	up to 400 mm
CPU Cooler Height	up to 155 mm
Supported Power Supply	ATX PSU
Cable management	behind mainboard tray, up to 18 mm
Dimension	487 x 205 x 480 mm (including front panel)
	467 x 205 x 430 mm (excluding front panel)

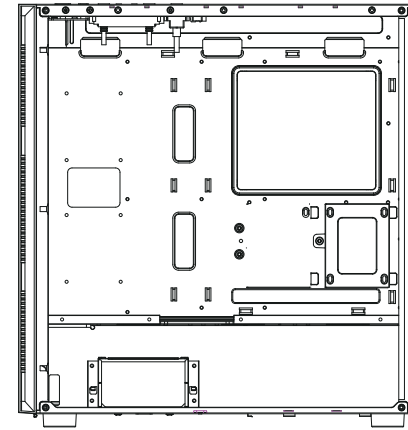
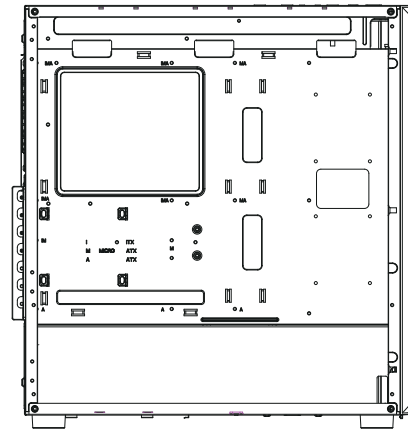

User Interface

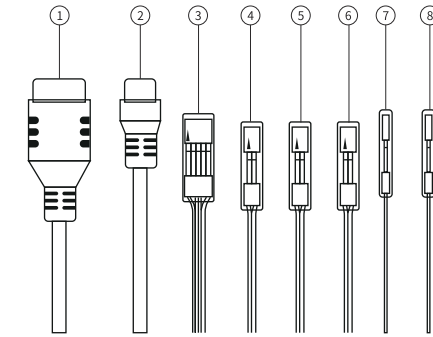
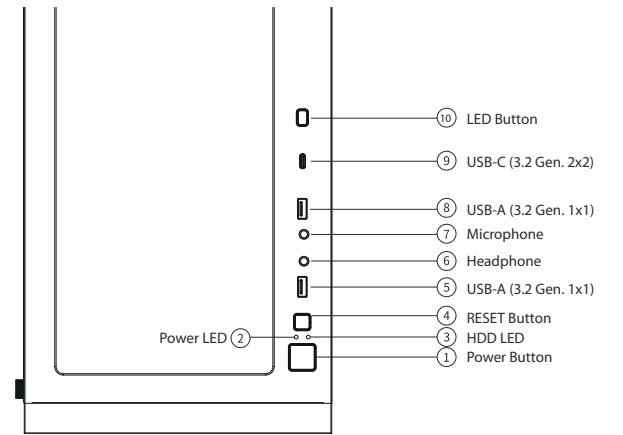

- 1 USB-A (3.2 Gen. 1x1)
- 2 USB-C (3.2 Gen. 2x2)
- 3 HD Audio
- 4 Power Switch
- 5 Reset Switch
- 6 HDD LED
- 7 Power LED +
- 8 Power LED -

Accessories

Type	Description	Quantity
1	Mainboard standoffs	3 pcs
2	Screws for power supply (PSU) / GPU / PCI slot	6 pcs
3	Screws for mainboard / 2,5" SSD	18 pcs
4	Screws for 3,5" HDD	9 pcs
5	Screws for GPU card on first PCI slot	2 pcs
6	Plastic spacer for fixing mainboard	3 pcs

Mainboard installation

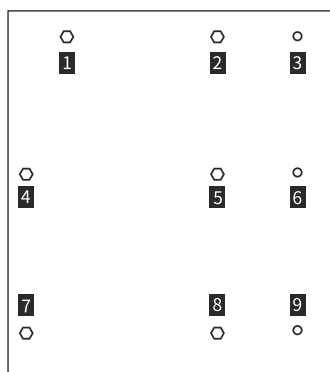

M/B Support



1. Open the left side panel, install the I/O shield
2. Install the mainboard standoffs (type 1) and plastic spacer (Type 6) at the corresponding positions according to the mainboard model.
3. Insert the mainboard and secure with screws (type 3)

Power Supply installation

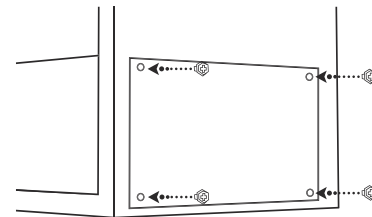

1. Open the right side panel
 2. The face down the fan of the PSU, then slide in the PSU into the power compartment.
 3. Secure the PSU with 4x screws (type 2)
- * Please refer to the power supply manual for the power cable connection method.

GPU installation

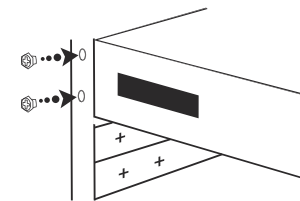

1. Remove metal plates on PCI slots
2. Insert GPU card
3. Secure the GPU card with screw (Type 5) on 1st PCI slot
4. Secure the GPU card with screw (Type 2) on 2-7 PCI slot

HDD/SSD installation in HDD/SSD bracket

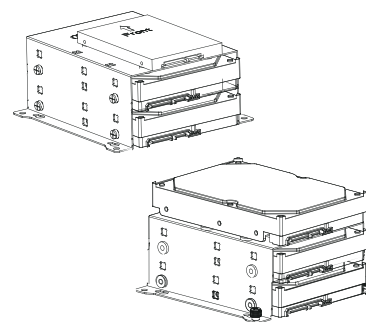

1. Remove the right side panel
2. Remove the HDD/SSD bracket out of the case (bottom) and slide the HDD tray out of the bracket
3. Secure the HDD or SSD to the trays with screws (Type 4 or Type 3)
4. Install the HDD/SSD bracket back to the case
5. Secure the HDD bracket with thumb screws

SSD installation behind main board plate (optional)

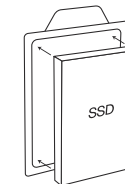

1. Remove right side panel and find the SSD brackets
2. Remove the SSD brackets by unsecure the screw
3. Secure the SSD at the back side of mainboard tray with 4x screws (Type 3)
4. Secure the SSD bracket with thumb screw

Service & notes

Avoid direct sunlight and a high temperature environment, keep the case far away from fire and heat sources.
Keep it in dry places, keep it away from corrosiveness causing materials.
The product has a two year warranty period from the date of purchase, service issues will be handled by your dealer.
If the case is damaged due to improper operation, the warranty period expires immediately.
Check www.lc-power.com or contact us by e-mail at: service@lc-power.com.

Silent Power Electronics GmbH
Formerweg 8, 47877 Willich, Germany
www.lc-power.com / service@lc-power.com / support@lc-power.com