

# ASUS NUC

NUC14RVK-B / NUC14RVH-B

迷你電腦/迷你电脑 Integration Guide

Regulatory Model: NUC14RVK 型號/型号: NUC14RVK



Regulatory Model: NUC14RVH 型號/型号: NUC14RVH



IG0001-001





# 1 TOOLS NEEDED

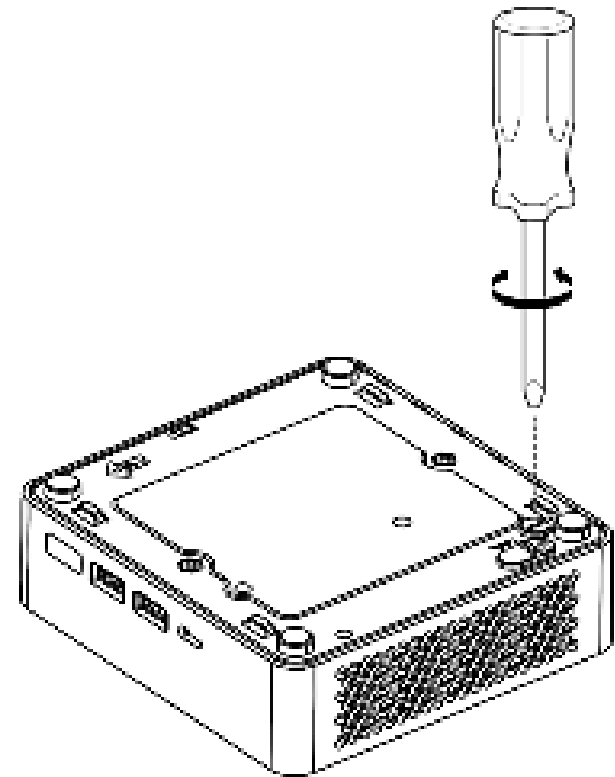
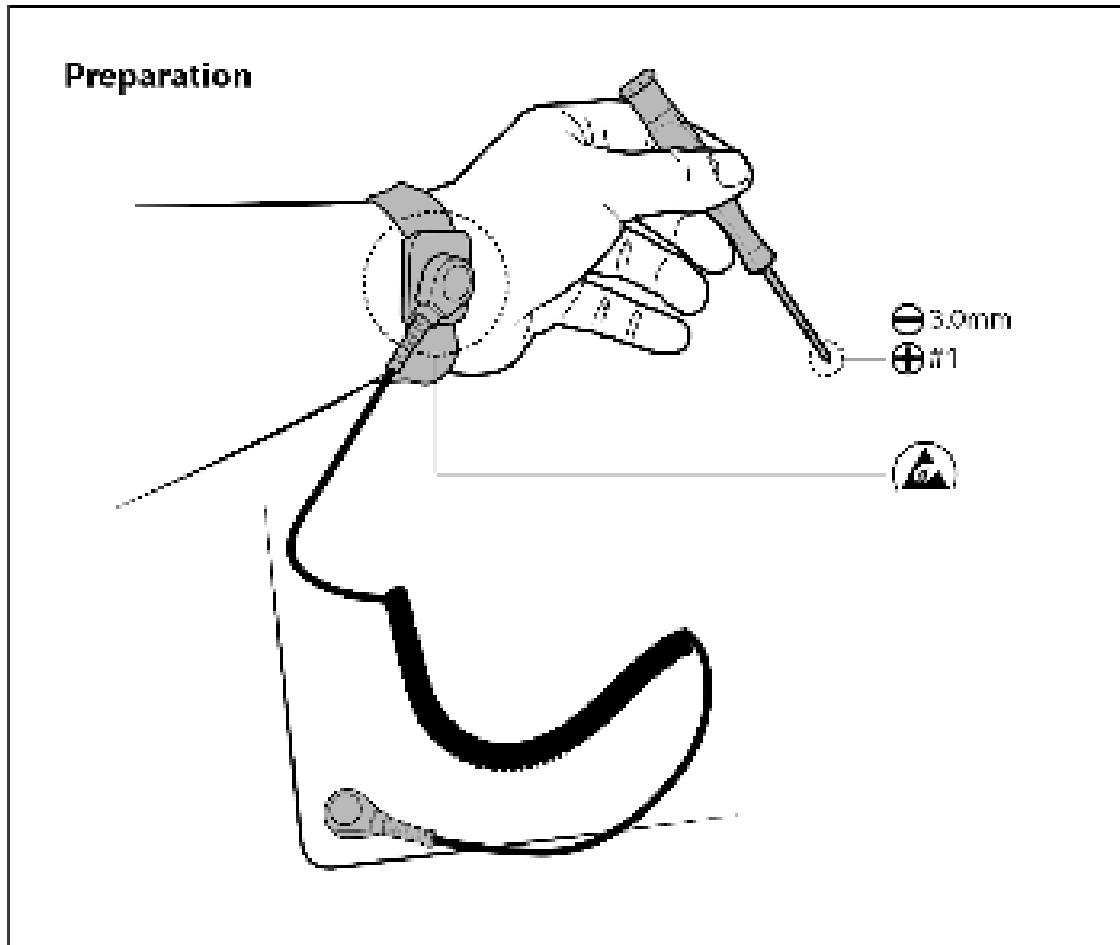

## 2 UNLOCK CHASSIS

---

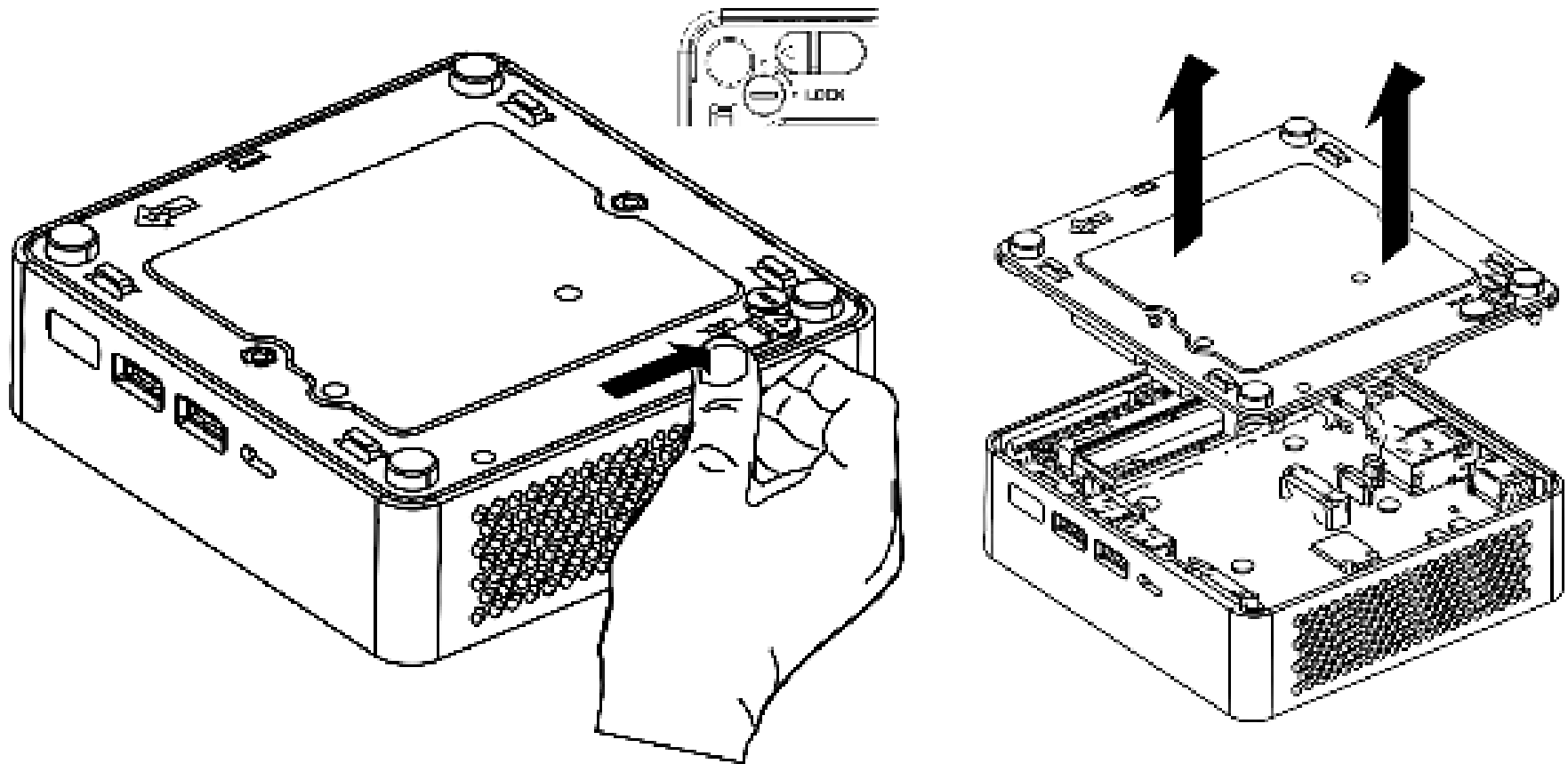

### 3 M.2 NVME 2280/2242 INSTALLATION

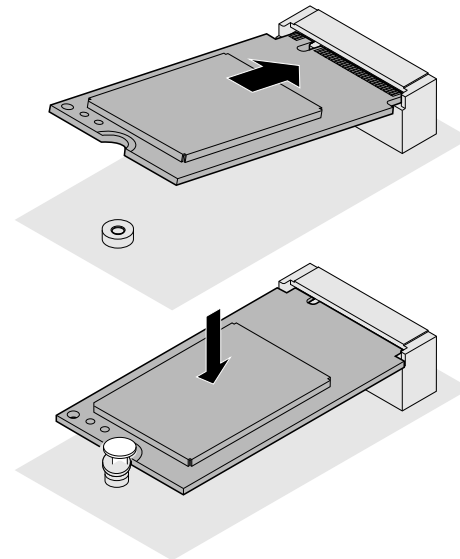
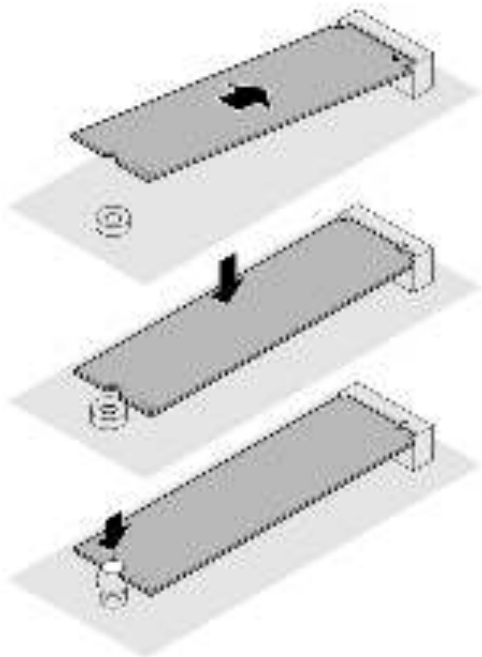
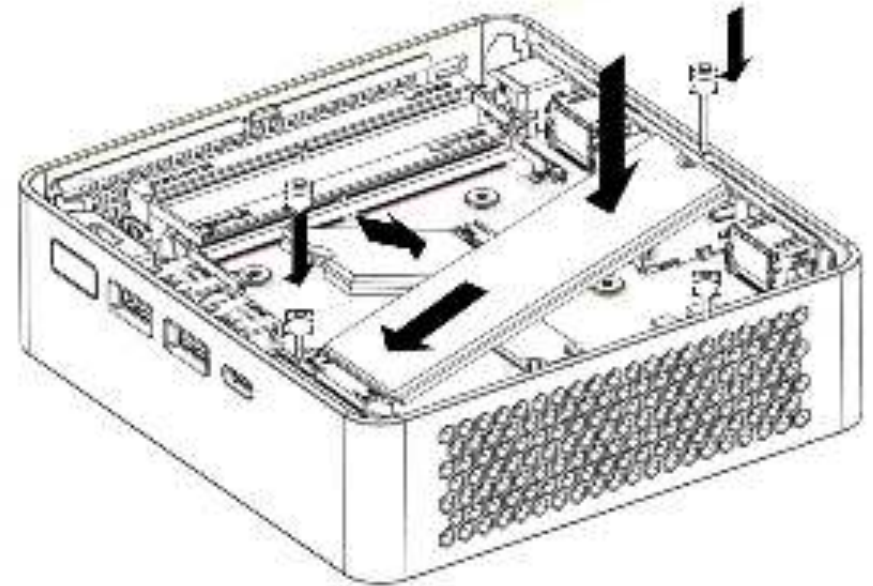
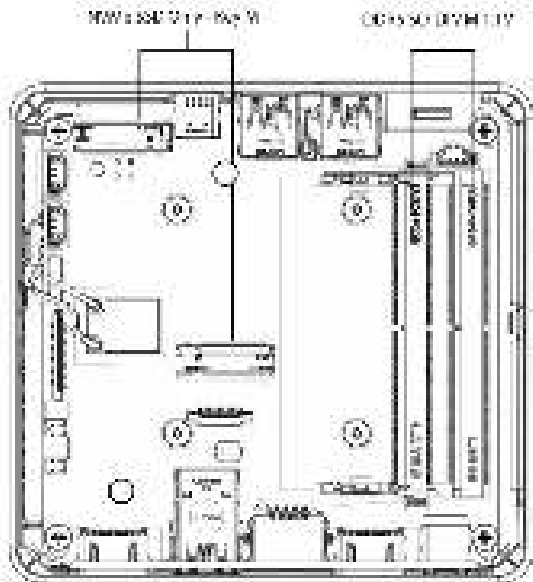

# 4 DDR5 INSTALLATION

---

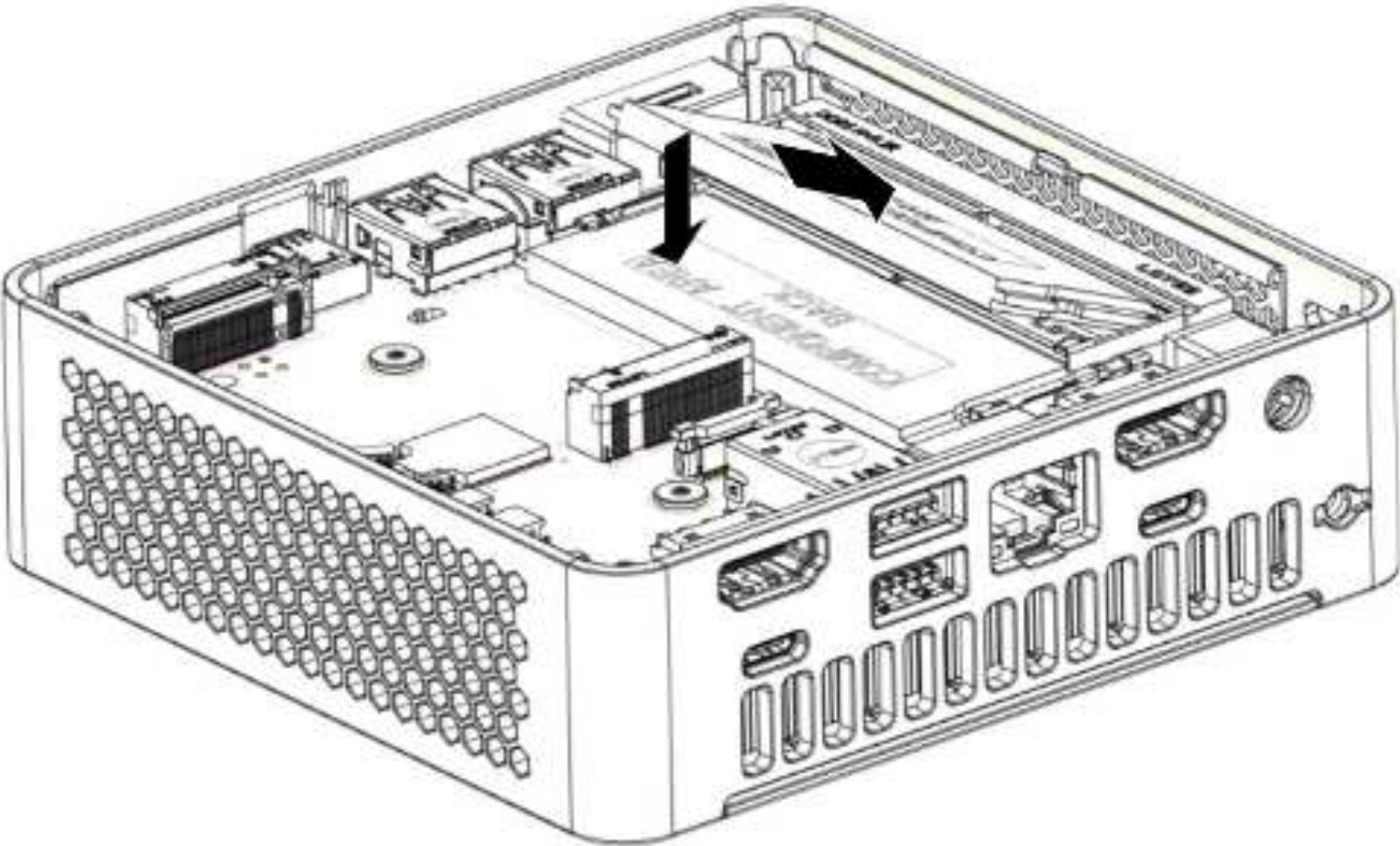

# 5 OPTIONAL 2.5" SATA INSTALLATION

---

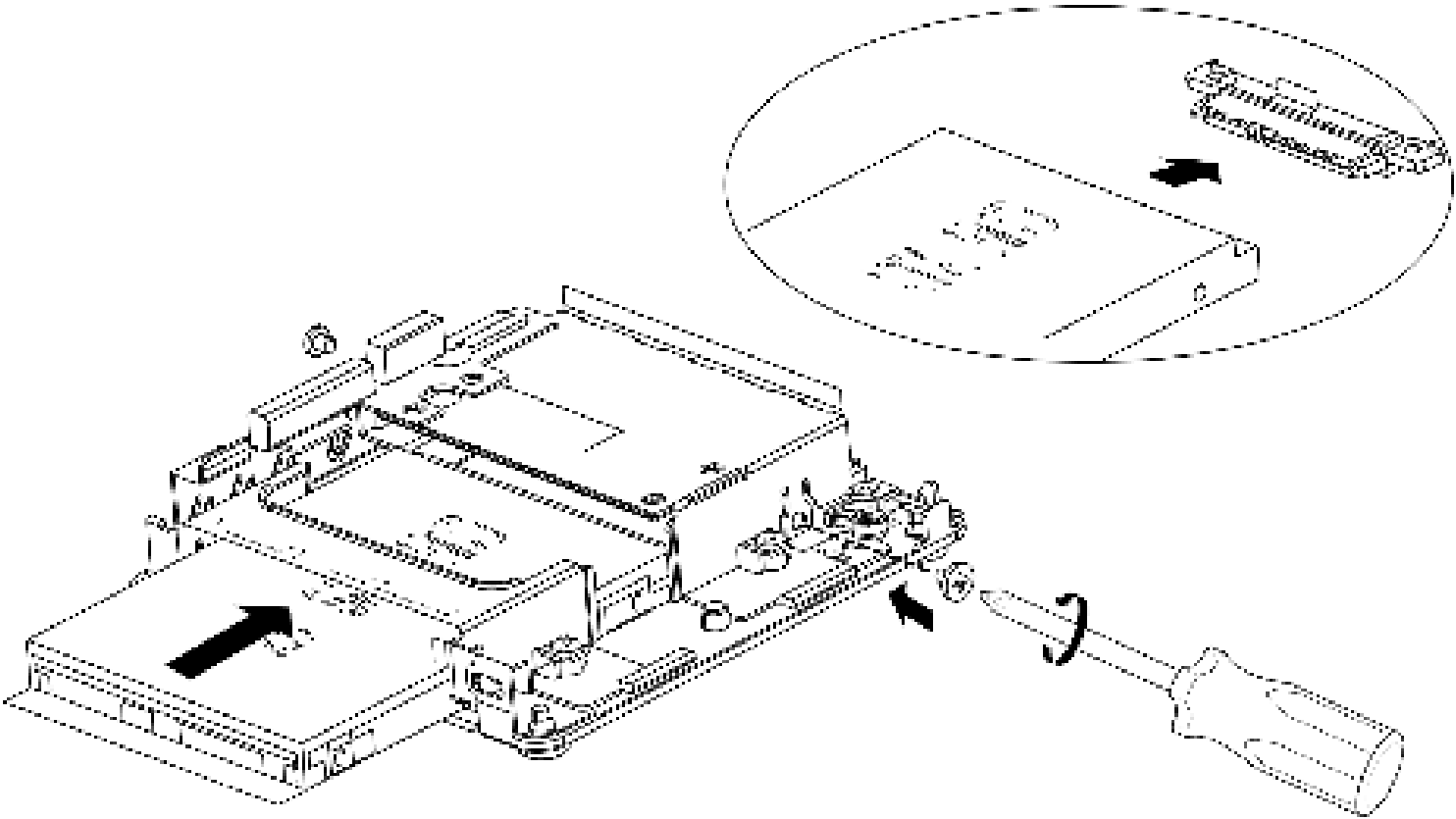



# 6 CLOSE AND LOCK CHASSIS

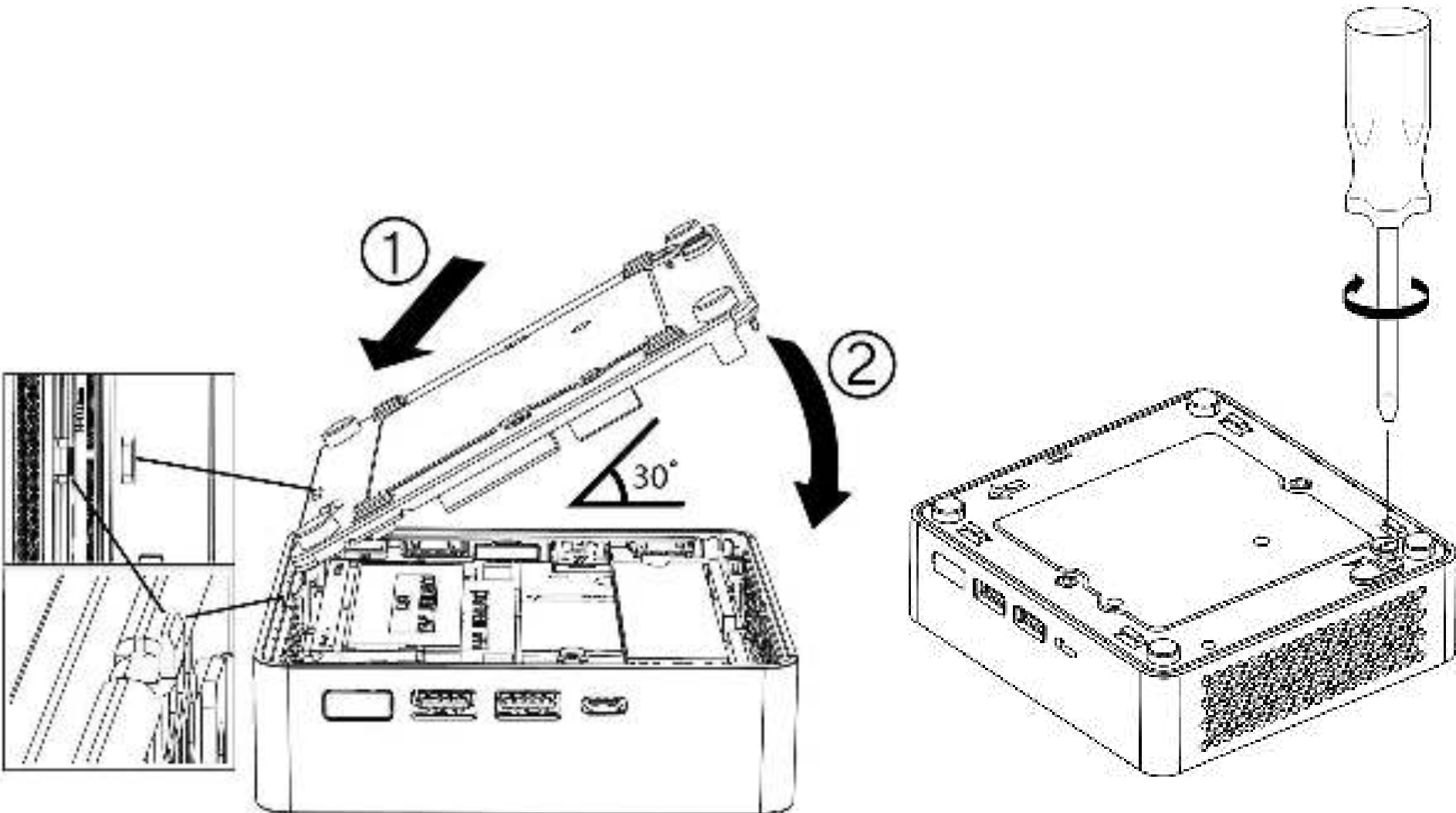

## 7 POWER INSTALLATION

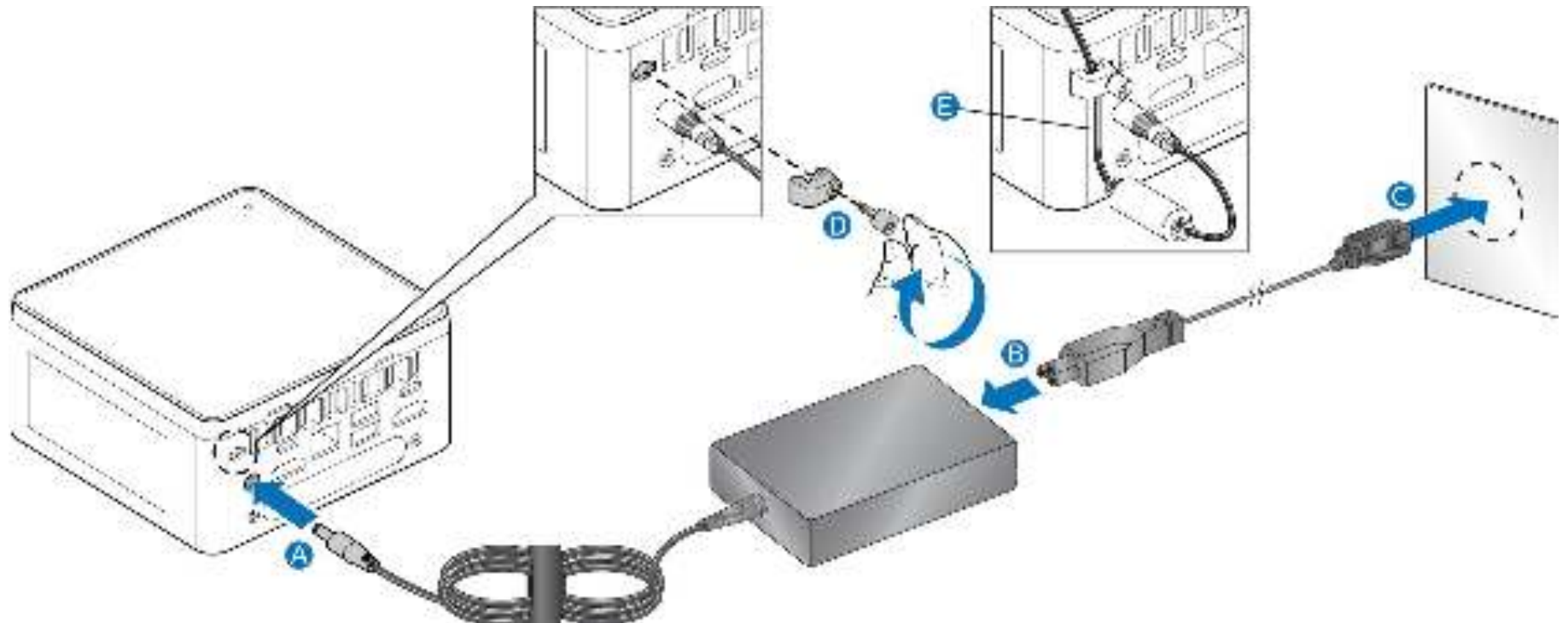

For a list of tested components and operating systems supported, go to the following web site: <https://www.asus.com/support/>

若要檢視測試的組件和受支援的作業系統列表，請訪問網站：<https://www.asus.com/support/>

若需已受測試的元件和作業系統清單，請造臨以下網站：<https://www.asus.com/support/>

Список протестированных компонентов и поддерживаемых операционных систем можно посмотреть на сайте <https://www.asus.com/support/>

Para ver una lista de los componentes sometidos a prueba y sistemas operativos compatibles, visite el siguiente sitio web: <https://www.asus.com/support/>

Pour obtenir une liste des composants testés et des systèmes d'exploitation pris en charge, consultez le site Web suivant : <https://www.asus.com/support/>

Eine Liste der getesteten Komponenten und unterstützten Betriebssysteme finden Sie auf der folgenden Website: <https://www.asus.com/support/>

Per un elenco dei componenti testati e dei sistemi operativi supportati, visitate il sito Web <https://www.asus.com/support/>

テスト済みのコンポーネントのリストと対応しているオペレーティング・システムについては、次の Web サイトをご覧ください：<https://www.asus.com/support/>

디스펜트 구성 요소와 지원되는 운영 체제 목록을 보려면 다음 웹 사이트로 이동하십시오: <https://www.asus.com/support/>

Aby uzyskać listę sprawdzonych składników i obsługiwanych systemów operacyjnych, przejdź do strony internetowej <https://www.asus.com/support/>

Para obter uma lista de componentes testados e sistemas operacionais compatíveis, acesse o website: <https://www.asus.com/support/>

Pour une liste des composants testés et des systèmes d'exploitation pris en charge, accédez au site Web suivant : <https://www.asus.com/support/>

За списком с тестовыми компонентами и поддерживаемыми операционными системами смотрите на следнии веб-сайте: <https://www.asus.com/support/>

Za popis ispitanih komponenti i podržanih operacijskih sustava, idite na sljedeću web stranicu: <https://www.asus.com/support/>

Seznam testovaných komponent a podporovaných operačních systémů naleznete na následující webové stránce: <https://www.asus.com/support/>

Hvis du vil have en liste over testede komponenter og understøttede systemer, skal du gå til følgende webside: <https://www.asus.com/support/>

Bezoek voor een lijst van geteste componenten en ondersteunde besturingssystemen de volgende website: <https://www.asus.com/support/>

Kontrollitud komponentide ja toetatud operatsioonisüsteemide loetelu leiate järgmiselt veebilehelt: <https://www.asus.com/support/>

Testattujen komponenttien ja tuettujen käyttöjärjestelmien luettelo on osoitteessa: <https://www.asus.com/support/>

Για μια λίστα των δοκιμασθέντων στοιχείων, και λειτουργικών συστημάτων που υποστηρίζονται, επισκεφθείτε την ακόλουθη διεύθυνση: <https://www.asus.com/support/>

A bevizsgált alkatrészek és a támogatott operációs rendszerek felsorolása ezen az oldalon található: <https://www.asus.com/support/>

Til að fá lista yfir prófaða hluti og stuðul stjórkerfi skal fara á eftirfarandi vefsetur: <https://www.asus.com/support/>

Pārbaudīto komponentu un atbalstīto operāciju sistēmu sarakstu skatiet vietnē: <https://www.asus.com/support/>

Išbandytų komponentų ir suderinamų operacinių sistemų sąrašą iškovkite šioje svetainėje: <https://www.asus.com/support/>

Текстоплане кувачување библиотечки може конаду керченленен авандек, куваченерен, таливи керу уане меке веб-сайтме кипејте: <https://www.asus.com/support/>

Du finner en liste over testede komponenter og operativsystemer som støttes, på nettsiden: <https://www.asus.com/support/>

Para acceder a una lista de componentes testados e de sistemas operativos soportados, visite el siguiente website: <https://www.asus.com/support/>

Per info o lista de componente testate și sisteme de operare acceptate, mergeți la următorul site web: <https://www.asus.com/support/>

Zoznam vyskúšaných komponentov a podporovaných operačných systémov nájdete na adrese: <https://www.asus.com/support/>

Seznam testiranih komponent in podržanih operacijskih sistemov najdete na naslednji spletni strani: <https://www.asus.com/support/>

Para acceder a la lista de componentes probados y sistemas operativos compatibles, vaya al siguiente sitio web: <https://www.asus.com/support/>

För en lista med testade komponenter och operativsystem som stöds, gå till följande websida: <https://www.asus.com/support/>

Test edilen bileşenlerin ve desteklenen işletim sistemlerinin listesini görmek için <https://www.asus.com/support/> web sitesine gidin.

Для просмотра списка протестированных компонентов и поддерживаемых операционных систем перейдите на страницу <https://www.asus.com/support/>

<https://www.asus.com/support/> için bilgiye ulaşmak için lütfen aşağıdaki adresi ziyaret edin.

اطلاع برای قائمة المكونات المدعومة وأنظمة التشغيل المدعومة، انتقل إلى الموقع التالي: <https://www.asus.com/support/>

Za spisak testiranih komponenti i podržanih operativnih sistema idite na sljedeću Internet stranicu: <https://www.asus.com/support/>

Untuk daftar komponen yang telah diuji dan sistem operasi yang didukung, kunjungi situs web berikut: <https://www.asus.com/support/>

For product support, go to: <https://www.asus.com/support/contact/troubleshooting/>

有关产品支持，请访问：<https://www.asus.com/support/contact/troubleshooting/>

如需查询故障排除方案，请访问：<https://www.asus.com/support/contact/troubleshooting/>

Відповісти на питання з технічної підтримки: <https://www.asus.com/support/contact/troubleshooting/>

Para obtener asistencia para productos, visite: <https://www.asus.com/support/contact/troubleshooting/>

Pour obtenir de l'assistance sur les produits, accédez à: <https://www.asus.com/support/contact/troubleshooting/>

Produktsupport finden Sie hier: <https://www.asus.com/support/contact/troubleshooting/>

Per assistenza sui prodotti, andare all'indirizzo: <https://www.asus.com/support/contact/troubleshooting/>

製品サポートについては、次の URL を参照してください。 <https://www.asus.com/support/contact/troubleshooting/>

제품 지원을 보려면 다음으로 이동하십시오: <https://www.asus.com/support/contact/troubleshooting/>

Aby uzyskać wsparcie dla produktu, odwiedź stronę: <https://www.asus.com/support/contact/troubleshooting/>

Para obter suporte ao produto, vá para: <https://www.asus.com/support/contact/troubleshooting/>

Pour du soutien technique, accédez à: <https://www.asus.com/support/contact/troubleshooting/>

За підтримку продукту перейдіть на: <https://www.asus.com/support/contact/troubleshooting/>

Za pomoćku proizvoda posjetite: <https://www.asus.com/support/contact/troubleshooting/>

Informacijska i/ili podrška produktu nalazi se na adresi: <https://www.asus.com/support/contact/troubleshooting/>

Produktsupport fås på: <https://www.asus.com/support/contact/troubleshooting/>

Ga voor productondersteuning naar: <https://www.asus.com/support/contact/troubleshooting/>

Toone tugiteenuste jaoks minge aadressile: <https://www.asus.com/support/contact/troubleshooting/>

Osobitsemise kohta: <http://www.intel.com/NUCSupport> on teie jaoks teie teie. <https://www.asus.com/support/contact/troubleshooting/>

На умовах ліцензії на програмне забезпечення: <https://www.asus.com/support/contact/troubleshooting/>

Terméktámogatás: <https://www.asus.com/support/contact/troubleshooting/>

Pytanie dotyczące produktu: <https://www.asus.com/support/contact/troubleshooting/>

Lei saņemtu produktu atbalstu, dodieties uz: <https://www.asus.com/support/contact/troubleshooting/>

Jei priekš savam produktam vēlaties saņemt palīdzību, apmekojiet: <https://www.asus.com/support/contact/troubleshooting/>

Өлчилжүүлэхийн тулд үүснэ, үүнийг цахим хуудалд очно: <https://www.asus.com/support/contact/troubleshooting/>

For produktstøtte, gå til: <https://www.asus.com/support/contact/troubleshooting/>

Para obter suporte para o produto, visite: <https://www.asus.com/support/contact/troubleshooting/>

Pemru asistenciã ou prãveirã la produs, mergeți la: <https://www.asus.com/support/contact/troubleshooting/>

Podpora produktov nãjdetã na adrese: <https://www.asus.com/support/contact/troubleshooting/>

Za pomoćku posjetite na: <https://www.asus.com/support/contact/troubleshooting/>

Para obtener asistencia sobre el producto, visite: <https://www.asus.com/support/contact/troubleshooting/>

For produktstøtte, gå til: <https://www.asus.com/support/contact/troubleshooting/>

Ürün desteği için bkz. <https://www.asus.com/support/contact/troubleshooting/>

Для отримання технічної підтримки для вашого обладнання перейдіть за посиланням <https://www.asus.com/support/contact/troubleshooting/>

<https://www.asus.com/support/contact/troubleshooting/> / <https://www.asus.com/support/contact/troubleshooting/> / <https://www.asus.com/support/contact/troubleshooting/>

للحصول من دعم المنتج، اذهب إلى: <https://www.asus.com/support/contact/troubleshooting/>

Za pomoćku za proizvod idite na: <https://www.asus.com/support/contact/troubleshooting/>

Untuk dukungan produk, kunjungi: <https://www.asus.com/support/contact/troubleshooting/>

To download the latest drivers and BIOS updates, go to: <https://www.asus.com/support/Download-Center/>

欲下載最新的驅動程式和 BIOS 更新，請前往: <https://www.asus.com/support/Download-Center/>

若要下載最新的驅動程式和 BIOS 更新，請前往: <https://www.asus.com/support/Download-Center/>

Загрузить последние версии драйверов и обновлений BIOS можно здесь: <https://www.asus.com/support/Download-Center/>

Para descargar las actualizaciones de BIOS y controladores más recientes, visite: <https://www.asus.com/support/Download-Center/>

Pour télécharger les derniers pilotes et mises à jour de BIOS, accédez à: <https://www.asus.com/support/Download-Center/>

Die aktuellen Treiber und BIOS-Updates können Sie hier herunterladen: <https://www.asus.com/support/Download-Center/>

Per scaricare i driver più recenti e gli aggiornamenti del BIOS, andare all'indirizzo: <https://www.asus.com/support/Download-Center/>

最新のドライバーと BIOS アップデートは、次の URL からダウンロードできます。 <https://www.asus.com/support/Download-Center/>

최신 드라이버와 BIOS 업데이트를 다운로드하려면 다음으로 이동하십시오. <https://www.asus.com/support/Download-Center/>

Aby pobrać najnowsze sterowniki i aktualizacje systemu BIOS, odwiedź stronę: <https://www.asus.com/support/Download-Center/>

Para baixar os drivers e as atualizações de BIOS mais recentes, vá para: <https://www.asus.com/support/Download-Center/>

Pour télécharger les dernières mises à jour de pilotes et du BIOS, accédez à: <https://www.asus.com/support/Download-Center/>

За да изтеглите най-новите драйвери и актуализации за BIOS, отидете на уебсайт: <https://www.asus.com/support/Download-Center/>

Za preuzimanje najnovijih upravljačkih programa i ažuriranja BIOS-a posjetite: <https://www.asus.com/support/Download-Center/>

Najnoviji aktualizacije softvera a systému BIOS si můžete stáhnout na adrese: <https://www.asus.com/support/Download-Center/>

Download de senaste drivrutinerna och BIOS-uppdateringar, gå till: <https://www.asus.com/support/Download-Center/>

Go voor de nieuwste drivers en BIOS updates naar: <https://www.asus.com/support/Download-Center/>

Välj senaste drivrutinerna och BIOS-uppdateringar på adressen: <https://www.asus.com/support/Download-Center/>

Vaik dažniausiai naujinti BIOS-įdiegimo adresu: <https://www.asus.com/support/Download-Center/>

Найнові драйвери та оновлення BIOS можна завантажити за адресою: <https://www.asus.com/support/Download-Center/>

A legújabb illesztőprogramokat és BIOS-frissítéseket innen lehet letölteni: <https://www.asus.com/support/Download-Center/>

TI, ad reiki najustu reiki na og BIOS-updates na hebi: <https://www.asus.com/support/Download-Center/>

Lai lejūgtūnātu jaunākos draiverus un BIOS atjauninājumus, dodieties uz: <https://www.asus.com/support/Download-Center/>

Jei norite atsisiųsti naujausius tvarkytuvius ir BIOS naujinius, apsilankykite: <https://www.asus.com/support/Download-Center/>

Самые последние драйверы и BIOS-обновления системы вы можете скачать по ссылке: <https://www.asus.com/support/Download-Center/>

For å laste ned de nyeste drivrutinerna og BIOS-oppdateringene, gå til: <https://www.asus.com/support/Download-Center/>

Para transferir as mais recentes atualizações de controladores e de BIOS, visite: <https://www.asus.com/support/Download-Center/>

Pentru a descărca cele mai recente drivere și actualizări de BIOS, mergeți la: <https://www.asus.com/support/Download-Center/>

Najnovšie aktualizácie softvérov a systému BIOS si môžete stáhnout na adrese: <https://www.asus.com/support/Download-Center/>

Za prístup najnovijih gonilnikov in posodobitev za BIOS pojdite na: <https://www.asus.com/support/Download-Center/>

Pour télécharger les actualisations de BIOS y controladores más recientes, visite: <https://www.asus.com/support/Download-Center/>

Hämta de senaste drivrutinerna och BIOS-uppdateringar, gå till: <https://www.asus.com/support/Download-Center/>

En son silindiciler ve BIOS güncellemelelerini karıştan yükleme için biz: <https://www.asus.com/support/Download-Center/>

Щоб завантажити найновіші драйвери та оновлення BIOS, перейдіть за наступним: <https://www.asus.com/support/Download-Center/>

<https://www.asus.com/support/Download-Center/> da juga BIOS-nya dapat diunduh secara langsung ke hard drive

<https://www.asus.com/support/Download-Center/> أو تنزيله مباشرة إلى القرص الصلب (BIOS) أو تنزيله مباشرة إلى القرص الصلب

Da biste preuzeli najnovije upravljačke programe i ažuriranja BIOS-a idite na: <https://www.asus.com/support/Download-Center/>

Untuk men-download pembaruan BIOS dan driver terbaru, kunjungi <https://www.asus.com/support/Download-Center/>





## 8 DISCLAIMER

---

### COPYRIGHT INFORMATION

No part of this manual, including the products and software described in it, may be reproduced, transmitted, transcribed, stored in a retrieval system, or translated into any language in any form or by any means, except documentation kept by the purchaser for backup purposes, without the express written permission of ASUSTeK COMPUTER INC. (“ASUS”).

ASUS PROVIDES THIS MANUAL “AS IS” WITHOUT WARRANTY OF ANY KIND, EITHER EXPRESS OR IMPLIED, INCLUDING BUT NOT LIMITED TO THE IMPLIED WARRANTIES OR CONDITIONS OF MERCHANTABILITY OR FITNESS FOR A PARTICULAR PURPOSE. IN NO EVENT SHALL ASUS, ITS DIRECTORS, OFFICERS, EMPLOYEES OR AGENTS BE LIABLE FOR ANY INDIRECT, SPECIAL, INCIDENTAL, OR CONSEQUENTIAL DAMAGES (INCLUDING DAMAGES FOR LOSS OF PROFITS, LOSS OF BUSINESS, LOSS OF USE OR DATA, INTERRUPTION OF BUSINESS AND THE LIKE), EVEN IF ASUS HAS BEEN ADVISED OF THE POSSIBILITY OF SUCH DAMAGES ARISING FROM ANY DEFECT OR ERROR IN THIS MANUAL OR PRODUCT.

Products and corporate names appearing in this manual may or may not be registered trademarks or copyrights of their respective companies, and are used only for identification or explanation and to the owners’ benefit, without intent to infringe.

SPECIFICATIONS AND INFORMATION CONTAINED IN THIS MANUAL ARE FURNISHED FOR INFORMATIONAL USE ONLY, AND ARE SUBJECT TO CHANGE AT ANY TIME WITHOUT NOTICE, AND SHOULD NOT BE CONSTRUED AS A COMMITMENT BY ASUS. ASUS ASSUMES NO RESPONSIBILITY OR LIABILITY FOR ANY ERRORS OR INACCURACIES THAT MAY APPEAR IN THIS MANUAL, INCLUDING THE PRODUCTS AND SOFTWARE DESCRIBED IN IT. Copyright © 2023 ASUSTeK COMPUTER INC. All Rights Reserved.

### LIMITATION OF LIABILITY

Circumstances may arise where because of a default on ASUS’ part or other liability, you are entitled to recover damages from ASUS. In each such instance, regardless of the basis on which you are entitled to claim damages from ASUS, ASUS is liable for no more than damages for bodily injury (including death) and damage to real property and tangible personal property; or any other actual and direct damages resulted from omission or failure of performing legal duties under this Warranty Statement, up to the listed contract price of each product. ASUS will only be responsible for or indemnify you for loss, damages or claims based in contract, tort or infringement under this Warranty Statement. This limit also applies to ASUS’ suppliers and its reseller. It is the maximum for which ASUS, its suppliers, and your reseller are collectively responsible. UNDER NO CIRCUMSTANCES IS ASUS LIABLE FOR ANY OF THE FOLLOWING: (1) THIRD-PARTY CLAIMS AGAINST YOU FOR DAMAGES; (2) LOSS OF, OR DAMAGE TO, YOUR RECORDS OR DATA; OR (3) SPECIAL, INCIDENTAL, OR INDIRECT DAMAGES OR FOR ANY ECONOMIC CONSEQUENTIAL DAMAGES (INCLUDING LOST PROFITS OR SAVINGS), EVEN IF ASUS, ITS SUPPLIERS OR YOUR RESELLER IS INFORMED OF THEIR POSSIBILITY. SERVICE AND SUPPORT Visit our multi-language website at <https://www.asus.com/support/>.